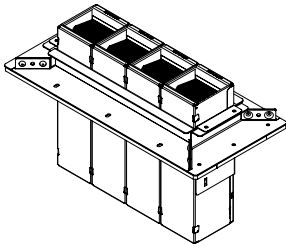
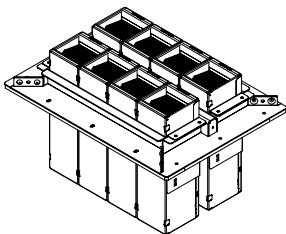


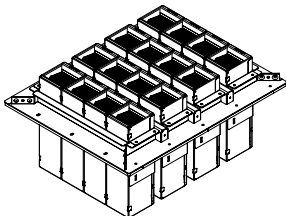
**Fig 1:** Complete Kits with Pathway Modules



EZDG444S & EZDG444S2



EZDG844S & EZDG844S2



EZDG1644S & EZDG1644S2

### DESCRIPTION

The EZ-Path Modular Floor Grid System is designed to facilitate the installation of multiple high-volume EZ-Path Series 44+ pathways through floors. The rugged, galvanized steel grid frame assembles quickly and easily and is bolted over pre-formed openings in concrete floors.

Pathways in banks of four, form modules that easily install through slots provided in the Grid. Grid sizes are available to accommodate one (1), two (2), or four (4) modules. All grid sizes may be purchased as complete kits including pathway modules (Fig 1). Multi-slot grids may be purchased with blank firestop filler panels (Fig 2) allowing modules to be purchased and installed at a later date as needed.

**Components:** See Table A below.

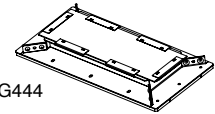
**NOTE:** Anchor fasteners are required to secure grid frame to floor and must be purchased separately. 3/16" x 1-1/4" concrete screws are recommended. See Table A for the number of fasteners required for the model chosen.

Floor grids (EZG444, EZG844 & EZG1644) include firestop filler panels to seal slots. Pathway module(s) (EZD444MBS or EZD444MBS2) must be purchased separately.

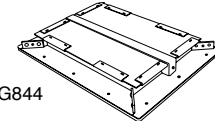
For additional information regarding components see the following Product Data Sheets:

- EZ-Path Series 44+ Fire Rated Pathway
- Spec-Seal® Intumescent Composite Sheet

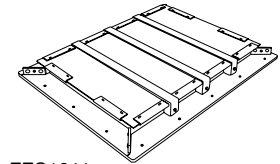
**Fig 2:** Grids with Firestop Filler Panels (No Pathway Modules)



EZG444

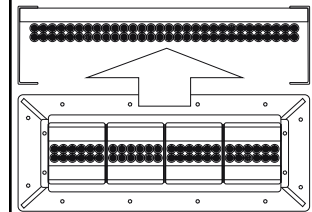


EZG844

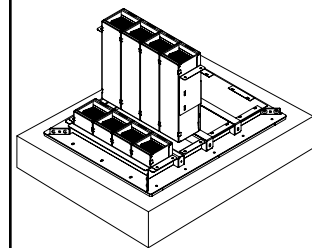


EZG1644

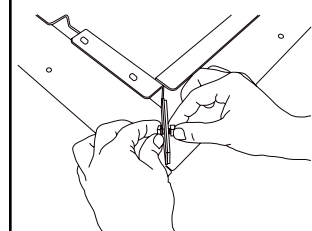
**Fig 3:** Grid Orientation



**Fig 4:** Installing on Raised Curb



**Fig 5:** Assemble Grid

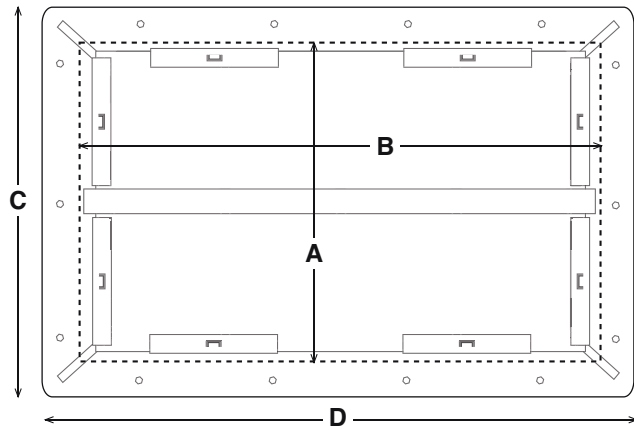


**TABLE A: Components**

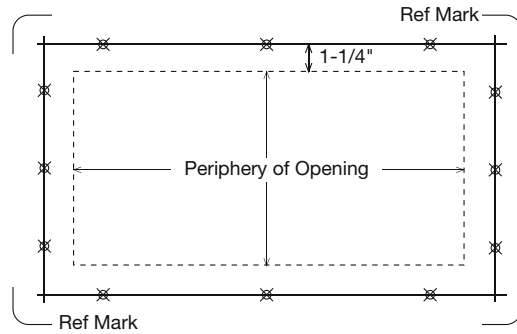
Model	Pathway Module (Four Pathways)	Firestop Panels	Panel Clips	Space Bar Assembly	Concrete Fasteners Not Included
EZDG444S / EZDG444S2	One (1) Included	NA	NA	NA	12
EZDG844S / EZDG844S2	Two (2) Included	NA	NA	One (1)	12
EZDG1644S / EZDG1644S2	Four (4) Included	NA	NA	Three (3)	16
EZG444	One (1) Purchase Separately	One (1)	Four (4)	NA	12
EZG844	Two (2) Purchase Separately	Two (2)	Eight (8)	One (1)	12
EZG1644	Four (4) Purchase Separately	Four (4)	Twelve (12)	Three (3)	16

<b>Grid Frame Assembly:</b>	Four Piece Grid Frame with gaskets Four (4) 1/4-20 x 1/2 Hex Bolts, Four (4) 1/4-20 x 1/2 Hex Nuts
<b>Pathway Module:</b>	Four (4) Series 44 Pathways One (1) RH Hanger Bracket, One (1) LH Hanger Bracket Four (4) 1/4-20 x 1/2 Hex Bolts, Four (4) 1/4-20 x 1/2 Hex Nuts
<b>Spacer Bar Assembly:</b>	One (1) Spacer Bar One (1) Spacer Strap One (1) Spacer Strap Gasket Two (2) 1/4-20 x 1/2 Hex Head Clamp Bolts

**Table B: Dimensions & Capacities**



**Fig 6: Marking corner reference and anchor points**



Pathway Capacity	Model (Catalog No.)		Module Capacity	Cable Capacity*	Opening Width (A)	Total Width (C)	Opening Length (B)	Total Length (D)
	With Modules	Without Modules						
4	EZDG444S / EZDG444S2	EZG444	1	875±	6" (15.3 cm)	11" (28 cm)	18" (45.7 cm)	23" (58.4 cm)
8	EZDG844S / EZDG844S2	EZG844	2	1750±	12" (30.5 cm)	17" (43.2 cm)	18" (45.7 cm)	23" (58.4 cm)
16	EZDG1644S / EZDG1644S2	EZG1644	4	3500±	24" (61 cm)	29" (73.7 cm)	18" (45.7 cm)	23" (58.4 cm)

NOTE: \*Nominal capacity using Cat 5E cables for reference.

## PREPARATION

**Orientation:** Grids are designed to be installed with slots running parallel to cable pathway or support systems such as vertical cable trays or racks (Fig 3).

**Floor Opening:** The EZ-Path Modular Floor Grid System installs into preformed, rectangular openings through concrete floors. Opening must be properly sized and positioned. Dimensions vary according to the model selected and are shown in Table B. Mounting of the grid frame requires an additional 2-1/2" of clear unobstructed space beyond the periphery of the opening on all sides. Where standing water or flooding is a concern, it is recommended that the grid frame be mounted to raised curbs formed into the concrete (Fig 4).

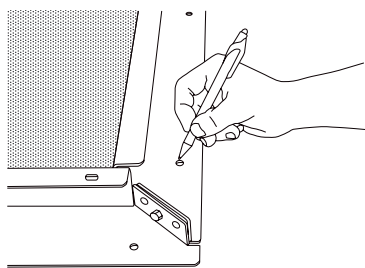
## INSTALLATION

**Assemble Grid Frame:** Assemble grid frame by installing 1/4-20 x 1/2" bolts and nuts through flanges at mitered corners (Fig 5).

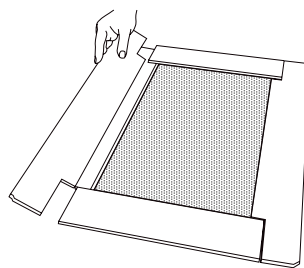
**Mark and Drill Anchor Holes:** Mark lines parallel to and an 1-1/4" from the periphery of the opening on all sides. Place assembled grid over opening so that these lines appear under anchor holes in frame on all four sides. Mark anchor holes and trace reference marks around the four outside corners of the grid frame (Figs 6 & 7). Remove frame and drill holes for anchors.

**Install Grid Frame:** Place gasket on concrete (Fig 8). Replace assembled grid frame back over opening using corner reference marks to reposition (Fig 9). Using concrete screw, probe through gasket to locate drilled holes. Install fastener loosely. Continue installing fasteners. When finished, tighten all fasteners securely.

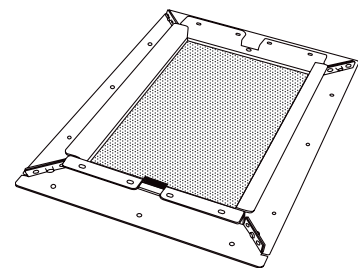
**Fig 7: Mark Anchor Points**

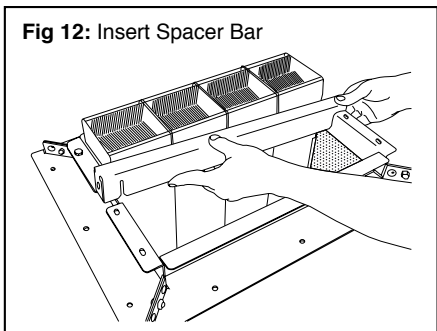
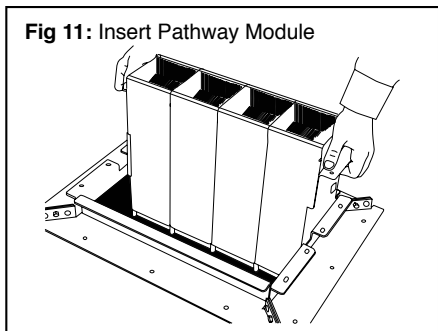
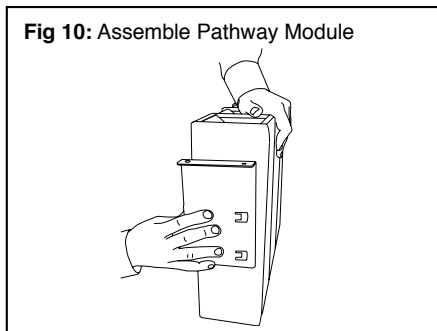


**Fig 8: Position Gaskets**



**Fig 9: Grid Frame Installed**





## PATHWAY MODULE INSTALLATION

**Assembling Pathway Modules:** Pathway Module (EZD444MBS or EZD444MBS2) includes four (4) Series 44+ EZ-Path Pathways along with right and left hanger brackets with nuts and bolts. Hook and eye attachment is used to join all pathways into a single bank. Install hanger brackets on both ends of the pathway bank (Fig 10).

**Insert Pathway Module** (Fig. 11) through grid slot and suspend by placing hanger brackets on side rails. Install and loosely tighten bolts and nuts (1/4 -20 x 1/2" provided). Install all pathway modules at this time using same procedure.

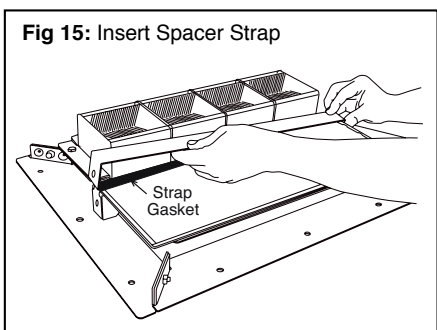
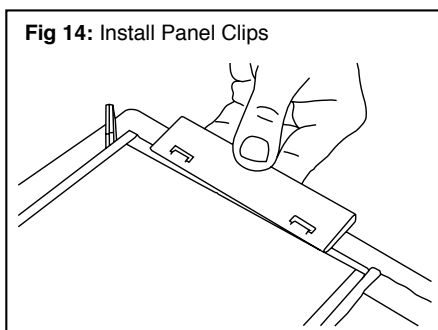
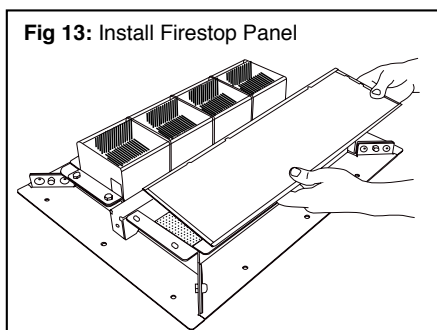
NOTE: For single slot grid frame (EZDG444S or EZDG444S2) it is necessary to loosen the mitered frame corner bolts to allow pathway module to be inserted. After inserting module, install and tighten hanger bracket bolts completely and then re-tighten bolts in frame corners.

**Install Spacer Bar Assembly:** In multi-slot grid frames, a spacer bar is used to separate pathway slots. After all pathway modules are in place, install spacer bar(s) (Fig 12) by aligning with notches in side rails located between pathway modules. Press down until top of spacer bar is flush with side rails.

Place spacer strap gasket in place over spacer bar. Install spacer strap over gasketed spacer bar, pressing strap down tightly against gasket. Install clamping bolts at each end and tighten to clamp spacer bar in place. Tighten pathway module bracket bolts (1/4 -20 x 1-1/2" provided).

**Installing Firestop Filler Panels:** Panels are used to seal any unused slots. If spacer bar(s) has been previously installed, remove spacer strap and gasket. Place panel over slot with sheet metal side facing up (Fig 13). Align edges of panel with frame rails and position to half-overlap spacer bar.

Holding panel securely in place with edges aligned, install panel clips (provided) at panel ends by pressing over lip of panel and frame flange (Fig 14). Drive clip on completely. Install clip at opposite end. Use two panel clips to secure long panel edge to grid frame. Replace spacer bar gasket and spacer bar strap (Fig 15) to secure panel edges where they overlap spacer bar. Reinstall and tighten spacer bar clamping bolts (Fig 16).



## ADDING PATHWAY MODULES

Additional cable capacity can be gained by installing Pathway Modules (EZD444MBS or EZD444MBS2) through unused slots in multi-slot grids. To add module, remove Firestop Filler Panel by removing panel clips as well as spacer bar clamping bolts and panel strap. Remove spacer bar. Install module (Fig 17) and reinstall spacer bar per instructions above.

## INSTALLING OR PULLING CABLES

A resilient liner provides an adjustable seal within the pathway device. Liner must be protected from damage while adding or removing cables. Wrap cable ends with a suitable low friction tape before inserting into the pathway. Where cable lubricants are used, low solids, water-based products are recommended. This device is designed to be fully functional at all cable loadings from completely empty to visually filled, and cables should easily slide through the pathway using minimal effort. IF RESISTANCE IS ENCOUNTERED, DO NOT FORCE CABLES OR CABLE BUNDLES THROUGH THE PATHWAY. DAMAGE MAY RESULT. Upper curved liner may be depressed when inserting cables, if necessary, using a flat, smooth implement and then removing it after cables are installed. The rectangular shape of the loading area coupled with gentle pressure exerted by resilient liners will naturally distribute the cables at a relatively uniform height across the width of the device. The use of a cable dressing/combining instrument to straighten and organize cables may help to maximize usable space within the pathway device.

## SUPPORTING CABLES

Allow slack where cables flow through pathways by providing support for cables above and below the floor. Cable support system should orient cables so that the flow is vertical through the center of the pathways.

## PRECAUTIONARY INFORMATION

The use of these products is subject to local, regional, and national codes. Consult the local Building Code Official or Authority Having Jurisdiction regarding any regional or local requirements that might influence the selection or use of this product.

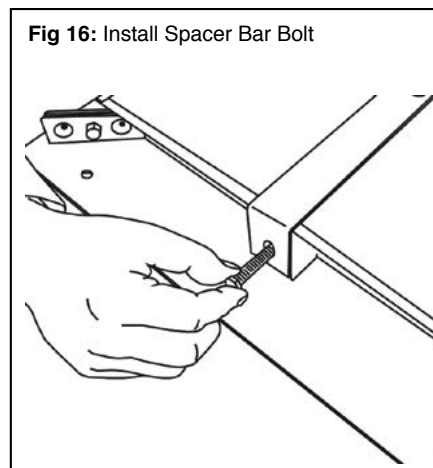


Fig 16: Install Spacer Bar Bolt

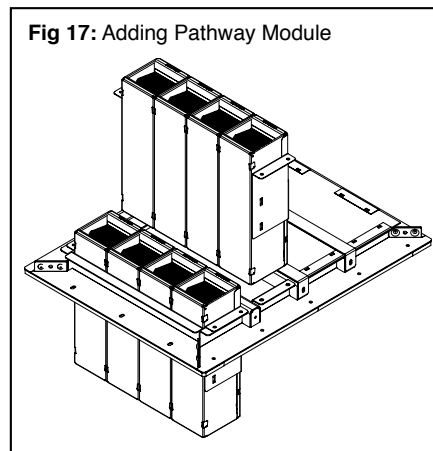


Fig 17: Adding Pathway Module

**IMPORTANT NOTICE:** All statements, technical information, and recommendations contained herein are based upon testing believed to be reliable, but the accuracy and completeness thereof is not guaranteed.

**WARRANTY:** Specified Technologies Inc. manufactures its goods in a manner to be free of defects. Should any defect occur in its goods (within one year), Specified Technologies Inc., upon prompt notification, will at its option, exchange or repair the goods or refund the purchase price.

**LIMITATIONS AND EXCLUSIONS:** THIS WARRANTY IS IN LIEU OF ALL OTHER REPRESENTATIONS EXPRESSED OR IMPLIED (INCLUDING THE IMPLIED WARRANTIES OF MERCHANTABILITY OR FITNESS FOR USE) AND UNDER NO CIRCUMSTANCES SHALL SPECIFIED TECHNOLOGIES INC. BE RESPONSIBLE FOR ANY INCIDENTAL OR CONSEQUENTIAL PROPERTY DAMAGE OR LOSSES. PRIOR TO USE, THE USER SHALL DETERMINE THE SUITABILITY OF THE PRODUCT FOR ITS INTENDED USE, AND THE USER ASSUMES ALL RISKS AND LIABILITY FOR SUBSEQUENT USE. No statement or recommendation not contained herein shall have any force or effect unless in an agreement signed by officers of seller and manufacturer.

MADE IN USA • PRINTED IN USA

Copyright © 2016 Specified Technologies Inc.



Somerville, NJ 08876 USA  
Phone: (800) 992-1180 Fax (908) 526-9623  
www.stifirestop.com