

ITEM NO.	DESCRIPTION	QTY.
1	ADAPTER, LC DUPLEX	6
2	SCREW, ADAPTER	12
3	DUST CAP, LC ADAPTER	24
4	NYLATCH PUSH FASTENER	2
5	FSP PANEL, 6-PORT, SC-STYLE	1

CATALOG NUMBER	DESCRIPTION
FSPLCDS6B	FSP PANEL WITH LC DUPLEX, BLUE
FSPLCDS6AQ	FSP PANEL WITH LC DUPLEX, AQUA
FSPLCDS6OR	FSP PANEL WITH LC DUPLEX, ORANGE
FSPLCDS6R	FSP PANEL WITH LC DUPLEX, RED
FSPLCDS6Y	FSP PANEL WITH LC DUPLEX, YELLOW
FSPLCDS6BK	FSP PANEL WITH LC DUPLEX, BLACK
FSPLCDS6BE	FSP PANEL WITH LC DUPLEX, BEIGE
FSPLCDS6GN	FSP PANEL WITH LC DUPLEX, GREEN
FSPLCDS6VI	FSP PANEL WITH LC DUPLEX, VIOLET

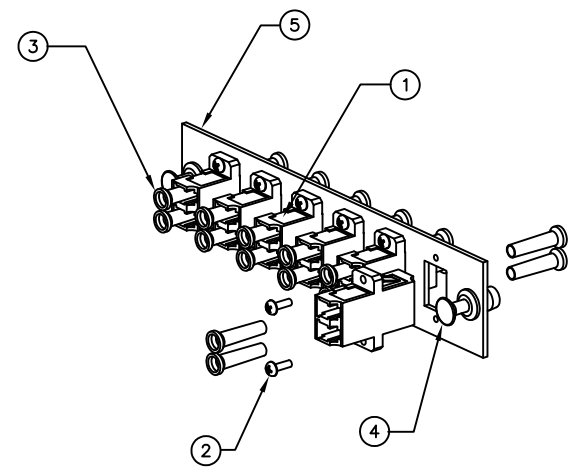
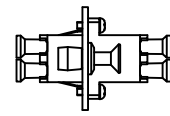
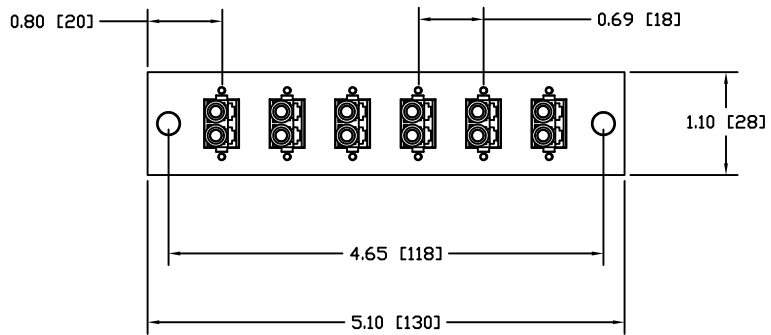
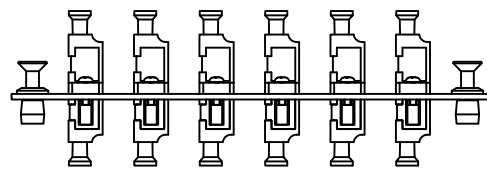

LOADED FSP PANEL

NOTES:

1. SUPPLIED WITH PUSH/PULL FASTENERS FOR EASY INSTALLATION/REMOVAL.
2. PANELS FIT INTO HUBBELL WALL MOUNT AND RACK MOUNT CABINETS.
3. BLACK ELECTROSTATICALLY APPLIED POWDER COAT.
4. ADAPTERS SUPPLIED WITH DUST CAPS INSTALLED
5. ZIRCONIA CERAMIC ALIGNMENT SLEEVES FOR HIGH PERFORMANCE APPLICATIONS.
6. SPECIFICATIONS SUBJECT TO CHANGE WITHOUT NOTICE.

Created on AUTOCAD	DIMENSIONING AND TOLERANCE PER ANSI Y14.5M-1982 UNLESS OTHERWISE SPECIFIED, DIMENSIONS ARE IN INCHES (MM). TOLERANCES .XX = ±.01 (.25) .XXX = ±.005 (.127) .XXXX = ±.0025 (.0635) ANGLE TOL ±1°		PROJECT REFERENCE: 066-07		 Hubbell Premise Wiring HUBBELL INCORPORATED (Delaware) 14 Lord's Hill Road, Stonington, Connecticut 06378	
	MATERIAL: PANEL: .0598" CRS WITH BLACK POWDER COAT FINISH		DRAWN BY: C. DUSSAULT 11/6/07			TITLE: FSP PANEL ASSEMBLY LC DUPLEX WITH 6 ZIRCONIA ADAPTERS
	IN ACCEPTING OUR DRAWINGS, BLUEPRINTS, OR SUPPORTING DOCUMENTATION FOR QUOTATION OR OTHER PURPOSES, YOU AGREE NOT TO DISCLOSE TO OTHERS THE IDEAS, INFORMATION, OR DESIGNS SHOWN HEREIN, AND THAT YOU WILL MAKE NO USE OF SAME WITHOUT PERMISSION		CHECKED BY: APPROVED BY:		SIZE: C DRAWING NO.: HWS12621C	REV.: E
			SCALE: N/A		SHEET 1 OF 1	

REV.	ECN	DATE	DESCRIPTION	CHG BY	APPD BY
E	21364	12/01/15	ADDED NEW CAT. NUMBER	JJRJ	