

PANDUIT P/N	WEIGHT
P16D20M	4.5kg

NOTES:

1. IDENTIFICATION:

UNIT TYPE:	MONITORED INPUT
ORIENTATION:	VERTICAL, HALF
OUTLET QTY&TYPE:	(16) 5-20R
BREAKER QTY&TYPE:	N/A
INPUT VOLTAGE:	100-120VAC
INPUT CURRENT:	16A (12A DERATED)
INPUT PHASE:	SINGLE-PHASE
RATED POWER:	1.9kVA
INPUT PLUG:	NEMA 5-15P
INPUT CORD LENGTH:	3m [10']

2. ACCESSORIES:

- POCKET GUIDE
- QTY: (4) M6 X 12 PAN HEAD MACHINE SCREWS
- QTY: (4) M6 CAGED NUT

3. RoHS COMPLIANT

4. VISIT PANDUIT'S ON-LINE CATALOG AT WWW.PANDUIT.COM FOR ADDITIONAL PRODUCT INFORMATION CONTAINED IN THE SPECIFICATION SHEET AS WELL AS A CURRENT LIST OF PRODUCTS APPLICABLE FOR USE WITH THIS PART

5. MAXIMUM ALLOWABLE INPUT POWER = 1.9kW

6. INSTALLATION SHALL COMPLY WITH ALL APPLICABLE NATIONAL, STATE, AND LOCAL CODES

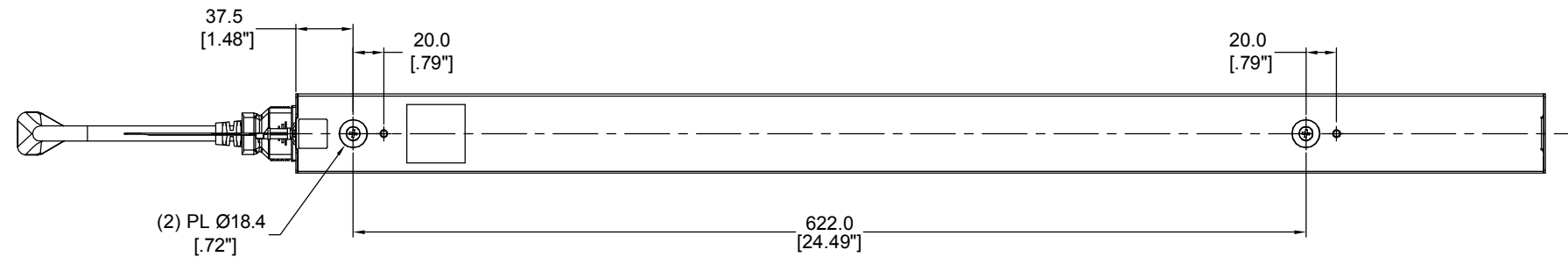

REAR VIEW

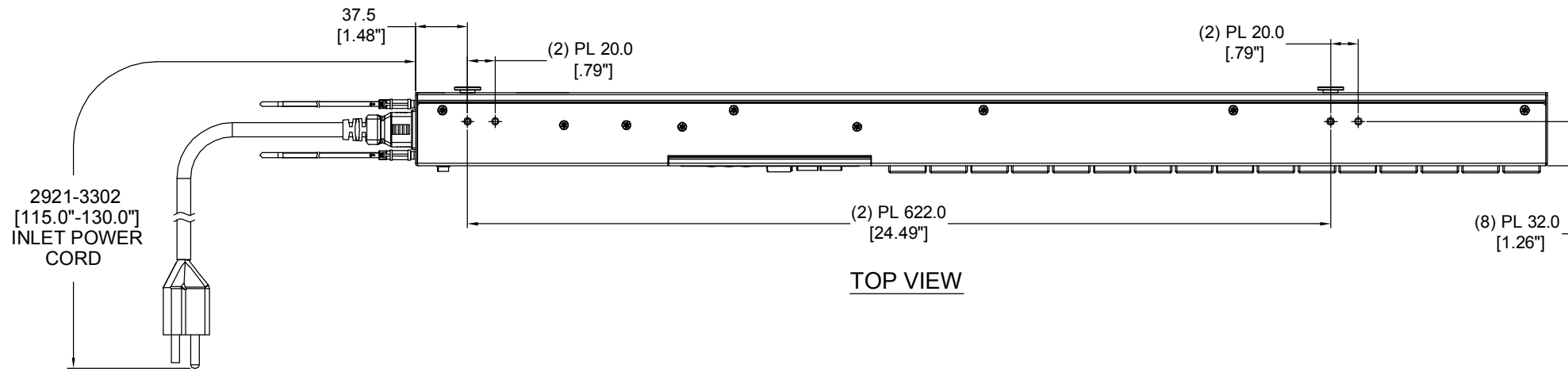

TOP VIEW

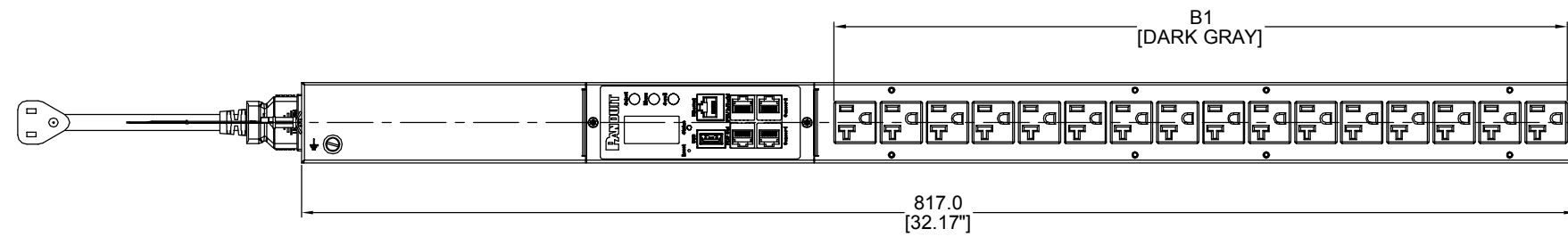

FRONT VIEW

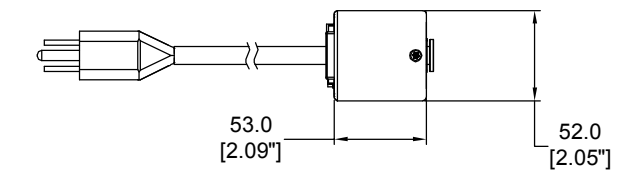

SIDE VIEW

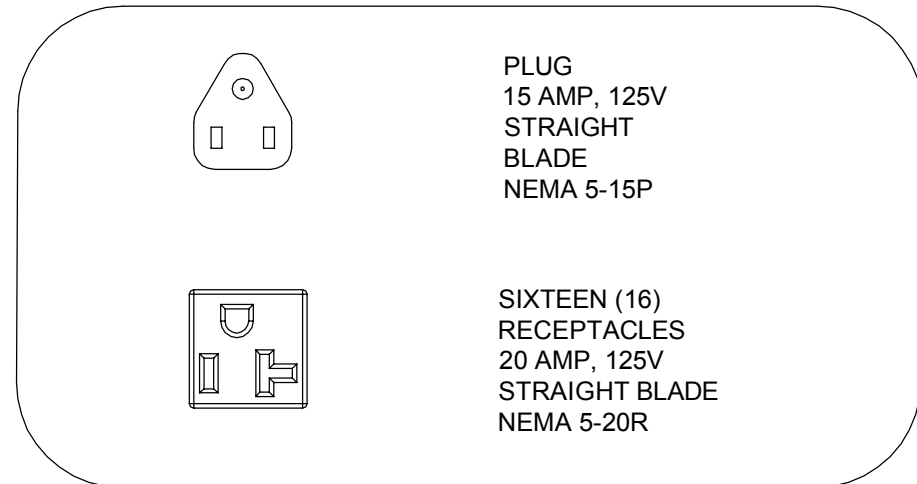

REV	DATE	BY	CHK	APR	DESCRIPTION	ECN
01A	07/19/2017	WSJ	MIM	EDM	INITIAL RELEASE	P16D20M

WE ASK THAT YOU CHECK FULLY THE DIMENSIONS, NOTES, AND SIGN THE CLIENT SIGNATURE BOX. THE JOB WILL NOT PROGRESS WITHOUT SIGNED APPROVAL. PLEASE DO NOT DELAY IN RETURNING PROOF AS IT WILL AFFECT DELIVERY		SIGN
		DATE
		PRINT
TITLE INTELLIGENT SERIES PDU P16D20M CUSTOMER DRAWING		
ITEM REVISION NAME		<b>PANDUIT</b>
DATASHEET FILE NAME:		
UNLESS OTHERWISE SPECIFIED DIMENSIONAL TOLERANCE ARE: mm [IN]		MATERIAL/COLOR: N/A
Tolerance(mm) 0<4<50 ±0.5 50<4<250 ±1.0 250<4<500 ±1.5 500<4<1000 ±2.5 1000<4<2000 ±4.0		DRAWING NUMBER: P16D20M_DC
DRAWN BY	DATE	SCALE
WSJ	07/19/2017	NONE
CHK	SEAN	SCALE
SHT 1 OF 1		B