

| BILL OF MATERIALS |                  |      |
|-------------------|------------------|------|
| ITEM NO.          | DESCRIPTION      | QTY. |
| 1                 | SIX PACK PANEL   | 1    |
| 2                 | NYLATCH FASTENER | 2    |

| CATALOG NUMBER | DESCRIPTION                  |
|----------------|------------------------------|
| FSPB           | BLANK SIX PACK ADAPTER PANEL |

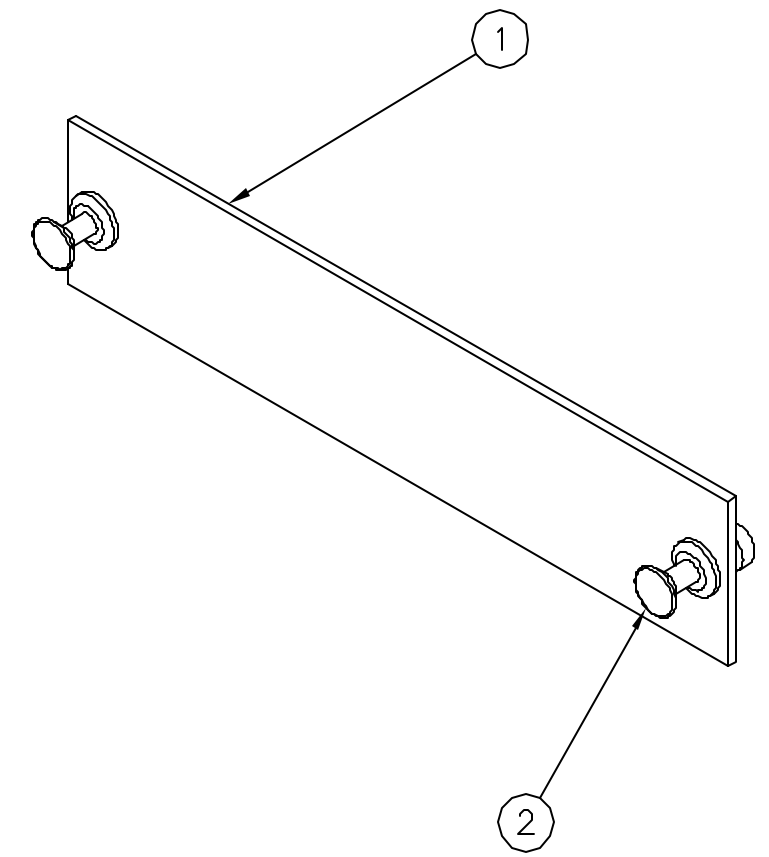
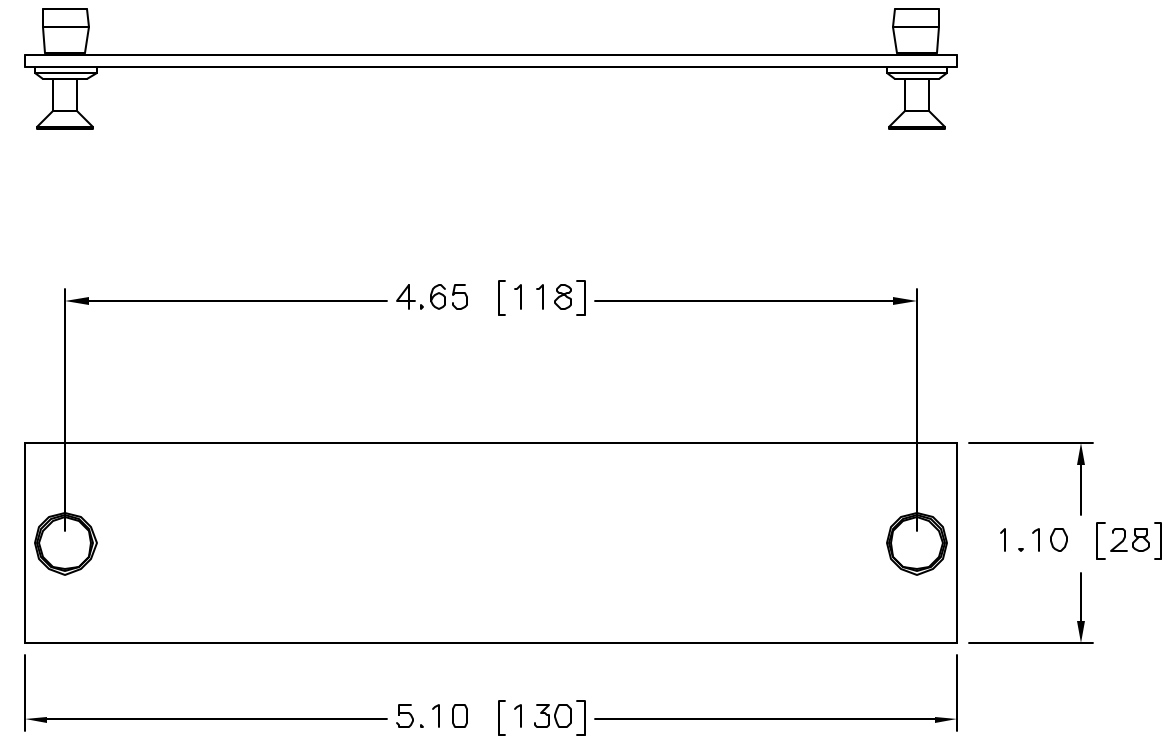

NOTES:

1. SUPPLIED WITH PUSH/PULL FASTENERS FOR EASY INSTALLATION/REMOVAL.
2. PANELS FIT INTO HUBBELL WALL MOUNT AND RACK MOUNT CABINETS.
3. BLACK ELECTROSTATICALLY APPLIED POWDER COAT.
4. SPECIFICATIONS SUBJECT TO CHANGE WITHOUT NOTICE.

| REV. | ECN  | DATE    | DESCRIPTION     | CHG BY | APPD BY |
|------|------|---------|-----------------|--------|---------|
| A    | 4446 | 01OCT01 | INITIAL RELEASE | PSM    |         |

|                    |   |   |
|--------------------|---|---|
| Created on AUTOCAD | DIMENSIONING AND TOLERANCE PER ANSI Y14.5M-1982 UNLESS OTHERWISE SPECIFIED, DIMENSIONS ARE IN INCHES (MM).<br>TOLERANCES<br>.XX = ±.01 (.25)<br>.XXX = ±.005 (.127)<br>.XXXX = ±.0025 (.0635)<br>ANGLE TOL ±1°                                    | PROJECT REFERENCE:                                    |
|                    | IN ACCEPTING OUR DRAWINGS, BLUEPRINTS, OR SUPPORTING DOCUMENTATION FOR QUOTATION OR OTHER PURPOSES, YOU AGREE NOT TO DISCLOSE TO OTHERS THE IDEAS, INFORMATION, OR DESIGNS SHOWN HEREIN, AND THAT YOU WILL MAKE NO USE OF SAME WITHOUT PERMISSION | MATERIAL:<br>.0598" CRS WITH BLACK POWDER COAT FINISH |
|                    |   | DRAWN BY:<br>PAUL S. MAGUIRE 01OCT01                  |
|                    |   | CHECKED BY:   |
|                    |   | APPROVED BY:  |

|  |  |                                     |                            |
|--|--|-------------------------------------|----------------------------|
|  <b>Hubbell Premise Wiring</b><br>HUBBELL INCORPORATED (Delaware)<br>14 Lord's Hill Road, Stonington, Connecticut 06378 |  | TITLE: BLANK SIX PACK ADAPTER PANEL |                            |
|  |  | SIZE: <b>B</b>                      | DRAWING NO.: <b>C11582</b> |
| SCALE: 1/1   |  | SHEET 1 OF 1                        |                            |