

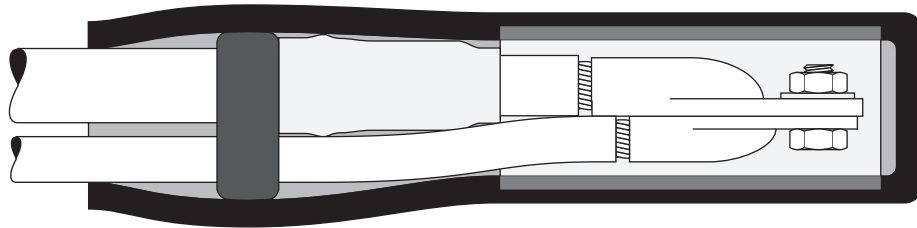

Motor Lead Pigtail or V-Stub Splice 5380 Series

For 5/8 kV Non-Shielded and Shielded Feeder Cables (Tape, Wire or UniShield® Cables)

Instructions



Kit Contents

- 3—Lug Covers
- 3—Cold Shrink Terminations
- 12—Mastic Sealing Strips
- 3—Copper Tape Strips
- 3—Cleaning Kits
- 6—Tubes Silicone Grease
- 3—Cold Shrink Jacket Tubes
- 3—Constant Force Springs

- 3—Cable Ties
- 3—Ground Straps
- 1—Instruction Sheet

Requires Vinyl Tape that is not in kit

Note: Visually inspect all components. If any component is missing or appears damaged, do not install. Call customer service at 1-800-245-3573 for a replacement product.

Kit Number	Cable Size Range (AWG/kcmil)		Feeder Cable Insulation O.D. Range	Max. Bolt Length	Max. Lug Length	ID of Boot to Size of Cables
	Feeder	Motor Lead				
5381	8 – 4	10 – 4	0.30 – 0.51" (7,6–13 mm)	5/8" (16 mm)	2 1/2" (63,5 mm)	0.90" (23 mm)
5382	2 – 1/0	4 – 1/0	0.43 – 0.65" (11–16,5 mm)	3/4" (19 mm)	2 3/4" (70 mm)	1.16" (29 mm)
5383	1/0 – 250	2 – 250	0.53 – 0.88" (13,5–22,4 mm)	1 1/4" (32 mm)	4" (102 mm)	1.60" (41 mm)
5384	250 – 500	4/0 – 500	0.75 – 1.12" (19–28,4 mm)	1 1/2" (38 mm)	5 1/2" (140 mm)	2.06" (52 mm)

Table 1

Technical Information:

- For shielded (Tape, Wire or UniShield®) and non-shielded cables
- Cable Size Range: Feeder: #8 AWG–500 kcmil
Motor Lead: #10 AWG–500 kcmil
- Copper Conductors

CAUTION

Working around energized systems may cause serious injury or death. Installation should be performed by personnel familiar with good safety practice in handling electrical equipment. De-energize and ground all electrical systems before installing product.

3M™ Motor Lead V-Stub Termination or Pigtail Splice Kits

For 5/8 kV Non-Shielded and
Shielded Cables

5381, 5382, 5383, 5384

78-8126-9102-6-B

Instructions for 5/8 kV Non-Shielded Feeder Cables

A. Prepare Cable According to Standard Procedures

Note: The terminations and grounding components will not be used for non-shielded cable.

1. Check to be sure cables fit within cable kit range as shown in Table 1 on cover.
2. Remove cable insulation for length recommended by terminal lug manufacturer; if no information is available, remove for depth of lug barrel.

B. Install Lugs

1. Clean insulation for approximately 6" using solvent-saturated cloths provided in kit.
2. Install and crimp lugs per manufacturer's direction. See back page if 3M™ lugs are used.

Figure 1

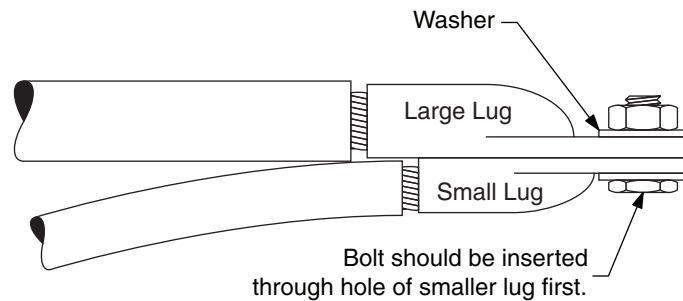

3. Bolt lugs together. See Table 1 on cover for maximum bolt length. See Figure 1 for proper bolt/lug arrangement.

C. Install Lug Cover

1. Separate cables and apply mastic strip between and around them, 3.5" (90 mm) from ends of cable insulations (Figure 2). Build mastic to an overall diameter that is greater than the inside diameter of the Lug Cover. Press cables together and make certain that no void exists between them (Figure 2).
2. Overwrap the mastic with 1 or 2 wraps of vinyl tape (Figure 2).

Figure 2

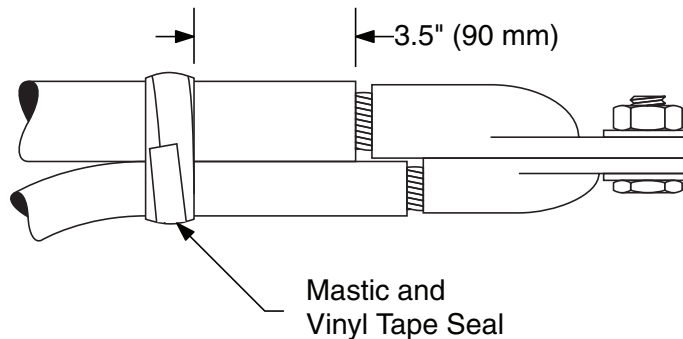

3. Install Lug Cover. Position Lug Cover so the punched holes are positioned between the cables (Figure 3).

Note: The kit contains a small tube of Silicone Grease. Use it to lightly lubricate the mastic and vinyl tape wraps. This will aid in the installation of the Lug Cover.

3.1 Be sure that the punched holes are beyond the cable end of the mastic and vinyl tape wrap. Insert the cable tie through the holes (Figure 3).

Hint: Inserting the cable tie from the back side of the Lug Cover will aid in visually aligning the cable tie through both holes.

3.2 Tighten the cable tie. Cut off excess length only if necessary. Cable ties are reusable.

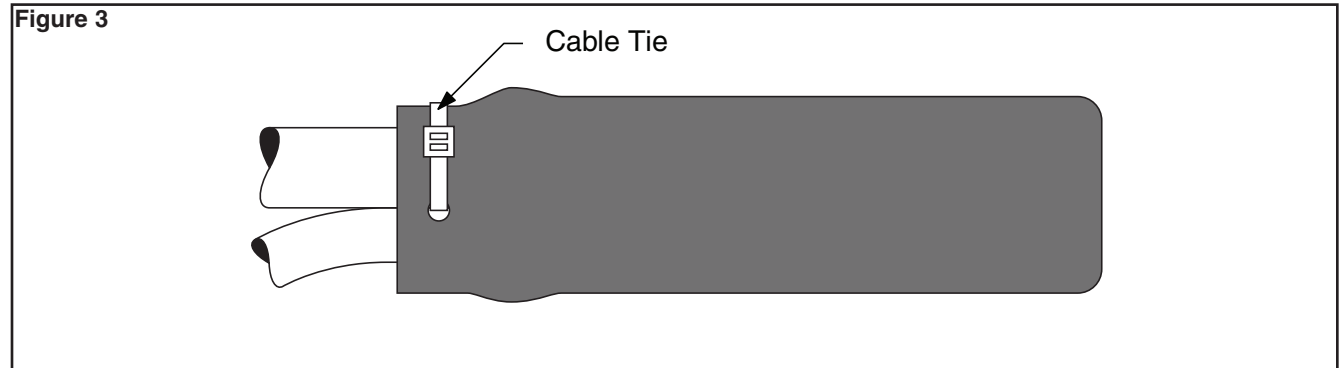

Instructions for 5/8 kV Shielded Feeder Cables for Non-Grounded Applications (Tape, Wire Shielded or UniShield® Cables)

A. Prepare Cable According to Standard Procedures

1. Check to be sure cables sizes fit within cable kit range as shown in Table 1 on cover.

For Non-Shielded Motor Lead Cable

2. Remove cable insulation for length recommended by terminal lug manufacturer; if no information is available, remove for depth of lug barrel.
3. Clean insulation for approximately 6" (150 mm) using solvent-saturated cloth provided in kit.

For Shielded Motor Lead Cable (if connection is to be grounded, see next section)

For Tape Shielded Cable see Figures 4a and 5a.

For Wire Shielded Cable see Figures 4b and 5b.

For UniShield® Cable see Figures 4c and 5c.

4. Prepare cable by removing jacket and shielding per dimensions as shown in Figure 4, depending on type of cable shielding. Apply copper tape strip over tape or wire shield to secure. See Figure 4a, 4b and 4c, depending on type of cable shielding.

Note: To ease jacket removal, install constant force spring as shown in Figure 23 and ring cut 80% through jacket. Remove jacket section by pulling against constant force spring. DO NOT BELL SEMI-CON JACKET. Remove constant force spring.

Some UniShield® cables feature dual-layer semi-conductive jackets. Both layers must be removed during cable preparation.

5. Remove cable insulation for length recommended by terminal lug manufacturer; if no information is available, remove for depth of lug barrel.

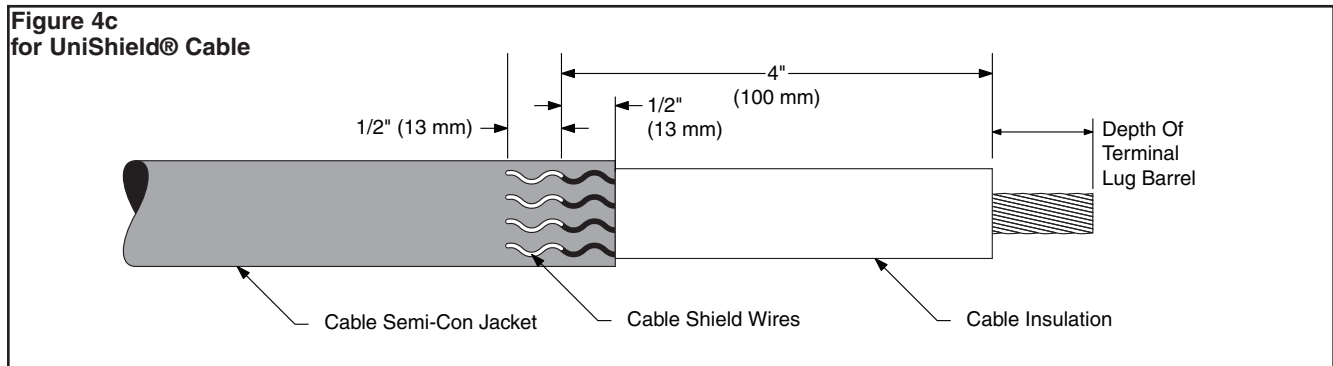
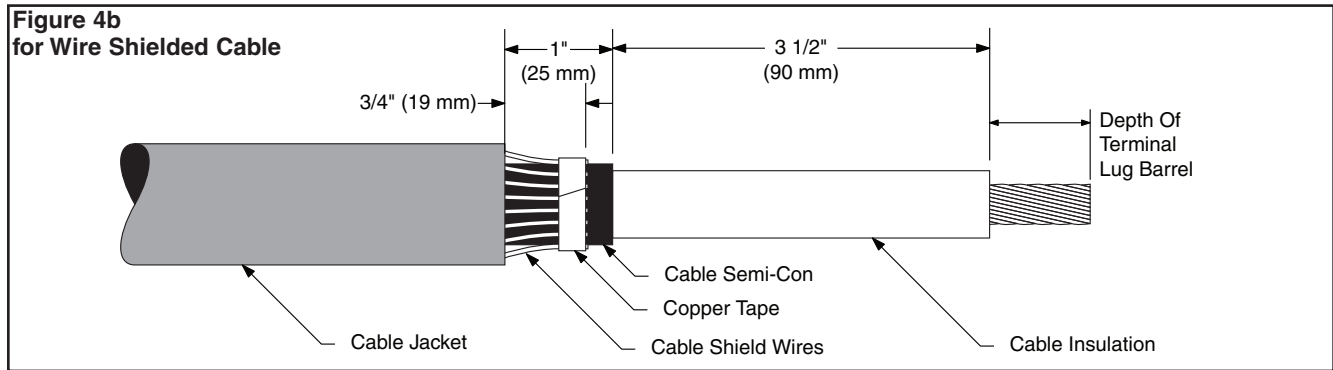
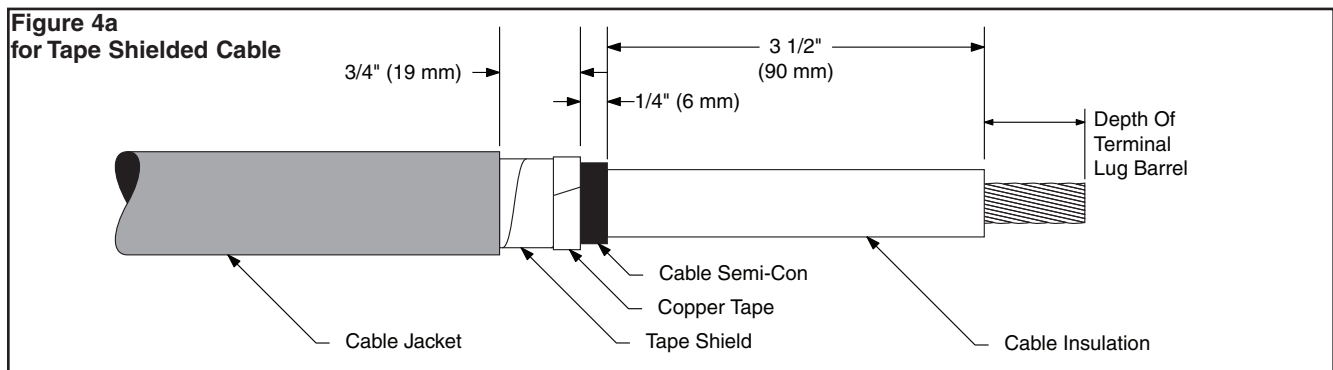

6. Clean cable insulation by using solvent-saturated cloths. **Do not allow solvent to touch cable semi-con.** If abrasive must be used to remove imbedded semi-con from cable insulation, use a non-conductive, 120-grit aluminum oxide, such as in the 3M™ Cable Prep Kit CC-2 or 3M Abrasive Roll A-3.

B. Install Termination

1. Install silicone grease at semi-con step and on cable insulation.

Note: Termination is in bag with copper tape strip.

2. Install termination beginning at cable jacket edge for tape or wire shielded cables. For UniShield® cables, begin 1" onto semi-con jacket.

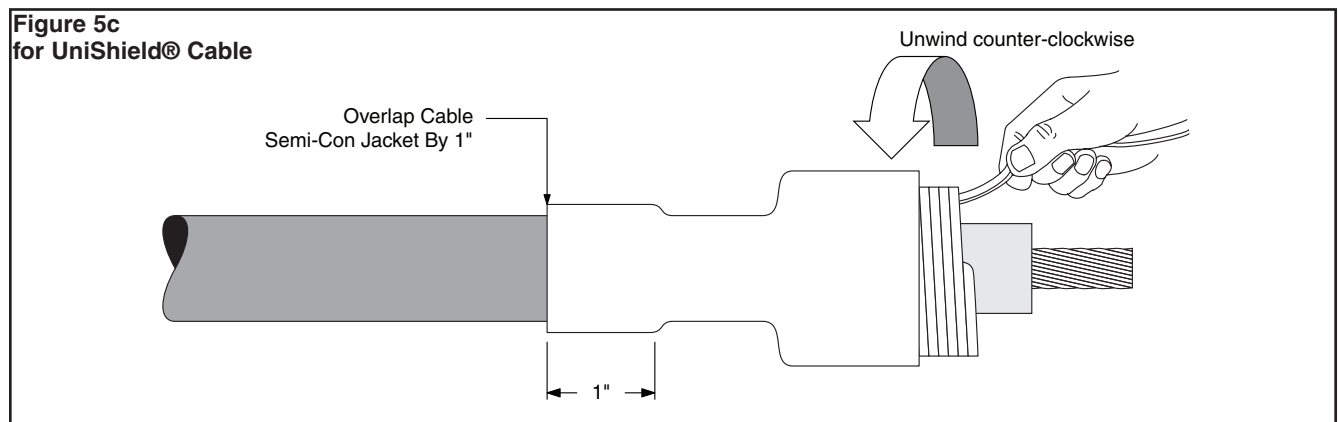
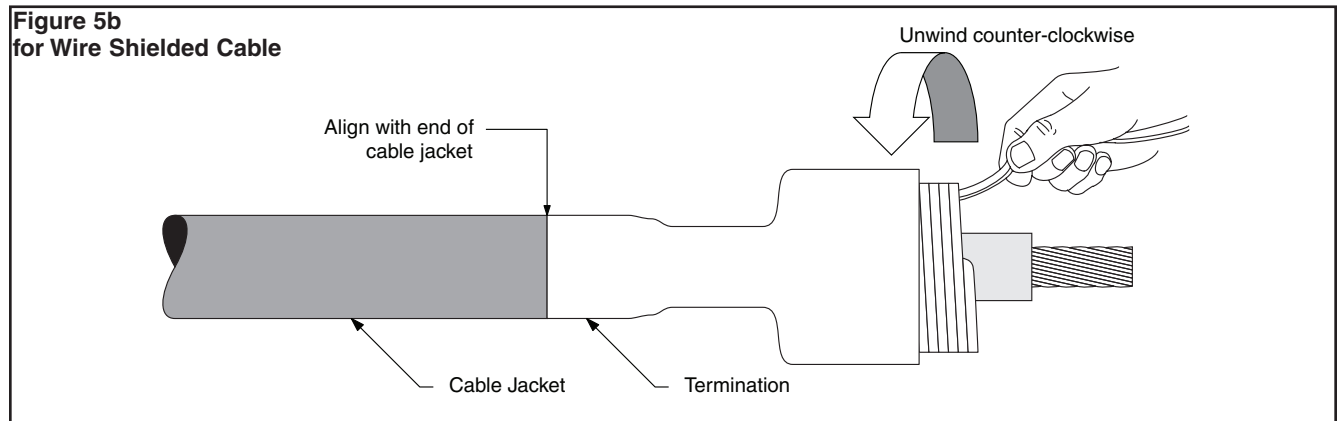
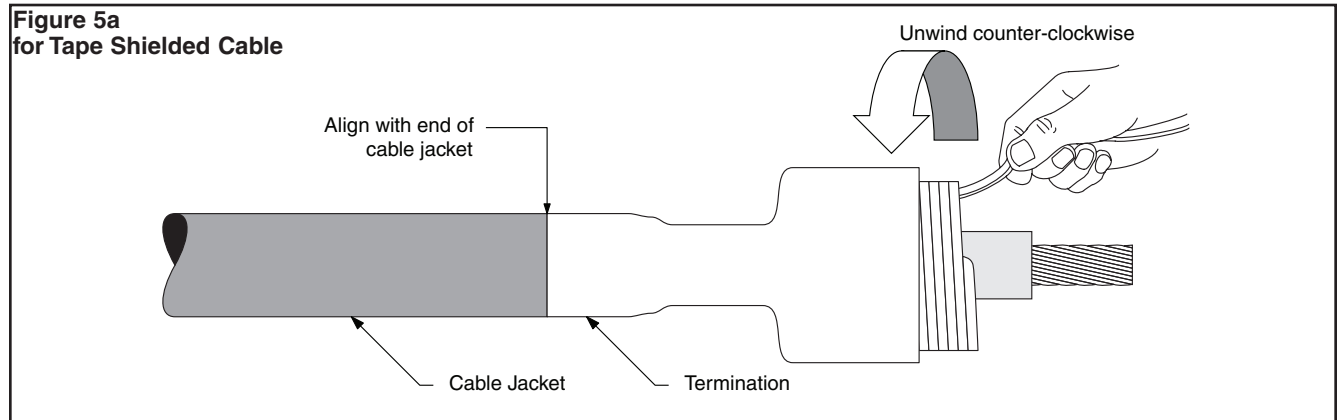

C. Install Lugs

1. Install and crimp lugs per manufacturer's direction; see back page if 3M™ Lugs are used.
2. Bolt lugs together. See Table 1 on cover for maximum bolt length. See Figure 6 for proper bolt/lug arrangement.

Figure 6

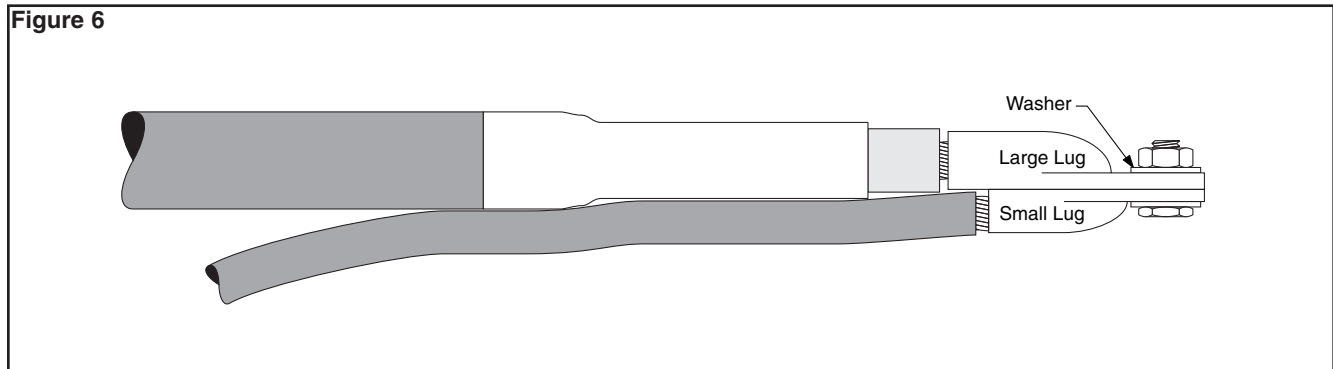

D. Install Lug Cover

1. Separate cables and apply mastic strip between and around them, centered over cable jacket and termination (Figure 7). Mastic will be on end of termination and cable jacket. Build mastic to an overall diameter that is greater than the inside diameter of the lug cover. Press cables together and make certain that no void exists between them (Figure 7).
2. Overwrap the mastic with 1 or 2 wraps of vinyl tape (Figure 7).

Figure 7

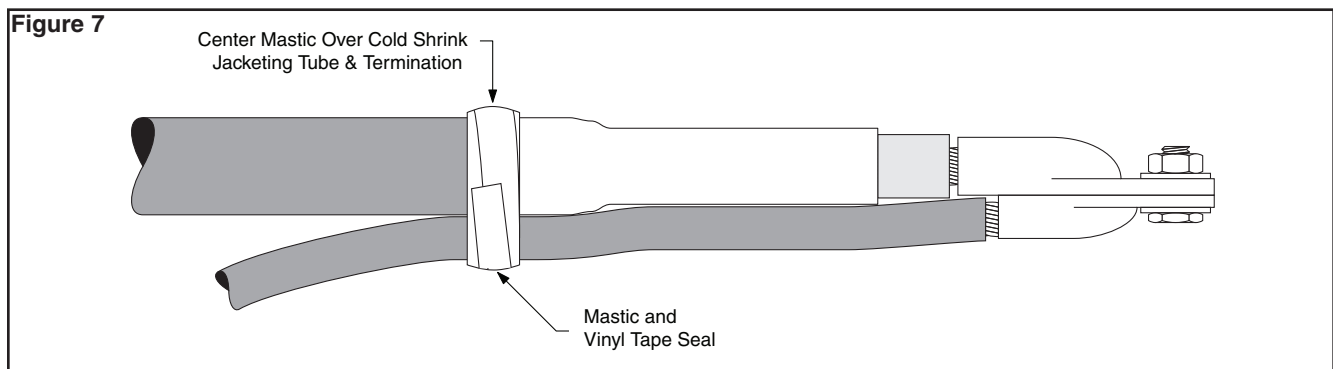

3. Install lug cover. Position lug cover so the punched holes are positioned between the cables (Figure 8)

Note: The kit contains a small tube of Silicone Grease. Use it to lightly lubricate the mastic and vinyl tape wraps. This will aid in the installation of the Lug Cover.

4. Be sure that the punched holes are beyond the cable end of the mastic and vinyl tape wrap. Insert the cable tie through the holes (Figure 8).

Hint: Inserting the cable tie from the back side of the lug cover will aid in visually aligning the cable tie through both holes.

5. Tighten the cable tie. Cut off excess length only if necessary. Cable ties are reusable.

Figure 8

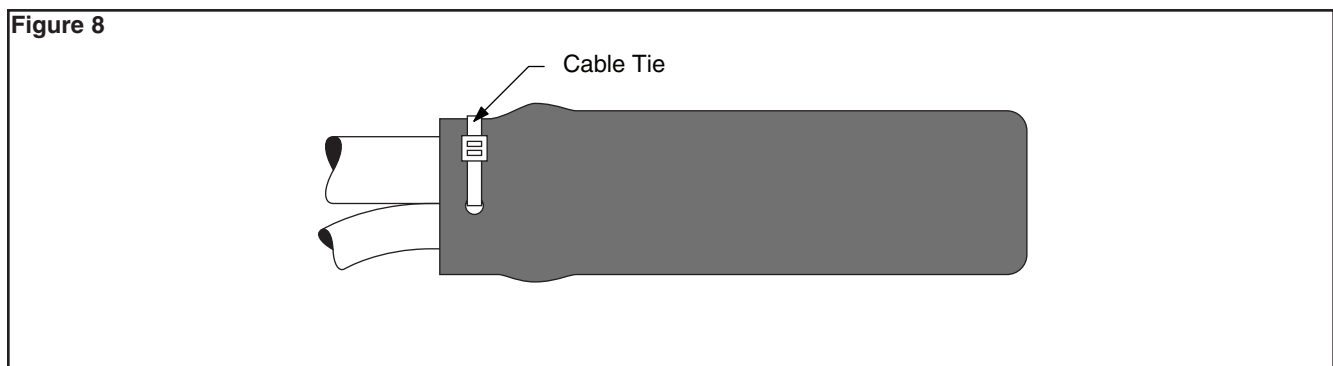

Instructions for 5/8 kV Shielded Feeder Cables With Ground Connection (Tape, Wire Shielded or UniShield® Cables)

A. Prepare Cable According to Standard Procedures

1. Check to be sure cables sizes fit within cable kit range as shown in Table 1 on cover.

For Non-Shielded Motor Lead Cable

2. Remove cable insulation for length recommended by terminal lug manufacturer; if no information is available, remove for depth of lug barrel.
3. Clean insulation for approximately 6" using solvent-saturated cloth provided in kit.

For Shielded Feeder Cable

For Tape Shielded Cable see item #4.

For Wire Shielded Cable see item #13, this section.

For UniShielded Cable see item #20, this section.

4. **For Tape Shielded Cables:** Prepare cable by removing jacket and shielding per dimensions as shown in Figure 9. Apply copper tape strip over tape shield to secure.
5. Remove cable insulation for length recommended by terminal lug manufacturer; if no information is available, remove for depth of lug barrel.

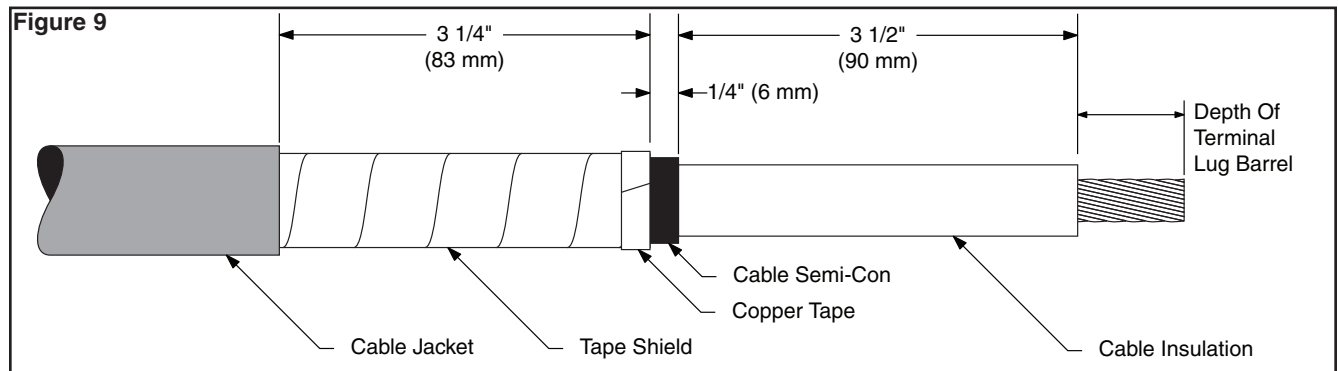

6. Clean cable insulation by using solvent-saturated cloths. **Do not allow solvent to touch cable semi-con.** If abrasive must be used to remove imbedded semi-con from cable insulation, use a non-conductive, 120-grit aluminum oxide, such as in the 3M™ Cable Prep Kit CC-2 or 3M Abrasive Roll A-3.
7. Select one mastic strip from kit and remove white release liners. Using light tension, apply a single wrap of mastic around the cable jacket 1/4" (6 mm) from cut edge (Figure 10). Cut off excess.

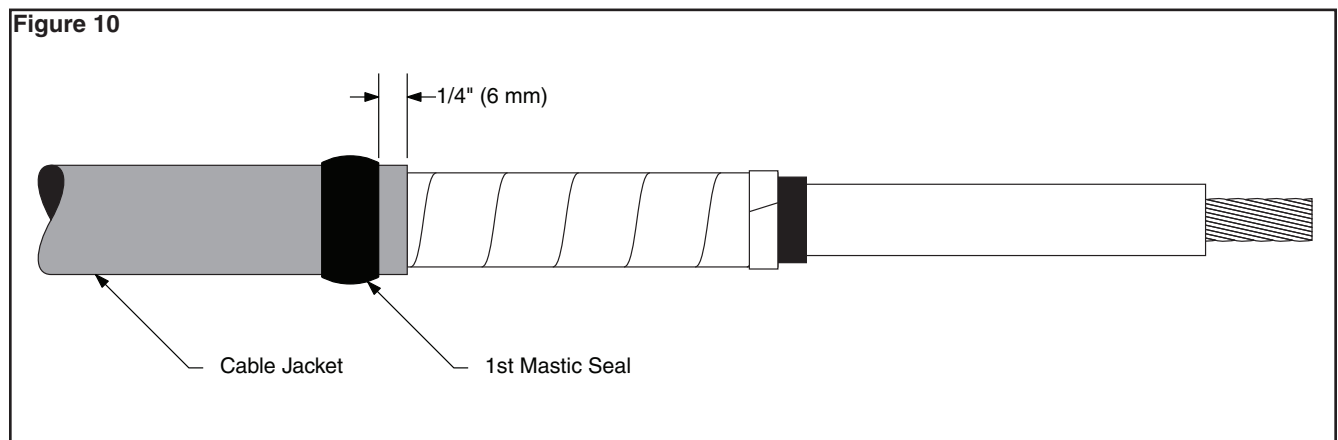

8. Position pre-formed ground braid with short tail over tape shield directly adjacent to cable jacket cut edge. Position long tail of ground braid, extending over cable jacket with solder block over mastic strip (Figure 11). Secure ground braid to cable jacket using vinyl tape at least 2" (50 mm) from edge of cable jacket (Figure 11).

Note: Ground braid, constant force spring and cold shrink jacket tube are in the same bag.

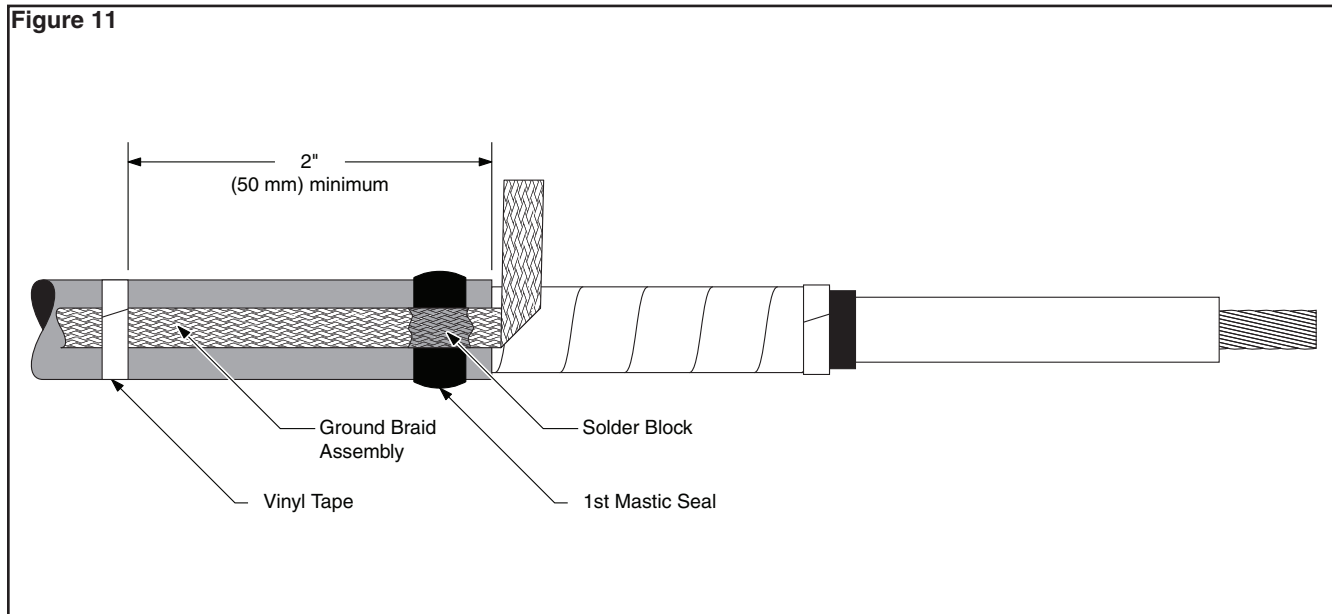

9. Wrap ground braid around cable tape shield one complete wrap, trim excess to prevent overlap and secure in place with constant force spring. Wrap spring in same direction as ground braid (Figure 12). Cinch (tighten) the spring after wrapping the final winding.
10. Select second mastic strip from kit and remove white release liners. Apply a second mastic band over solder block on ground braid and previously applied mastic (Figure 12) Cut off excess.

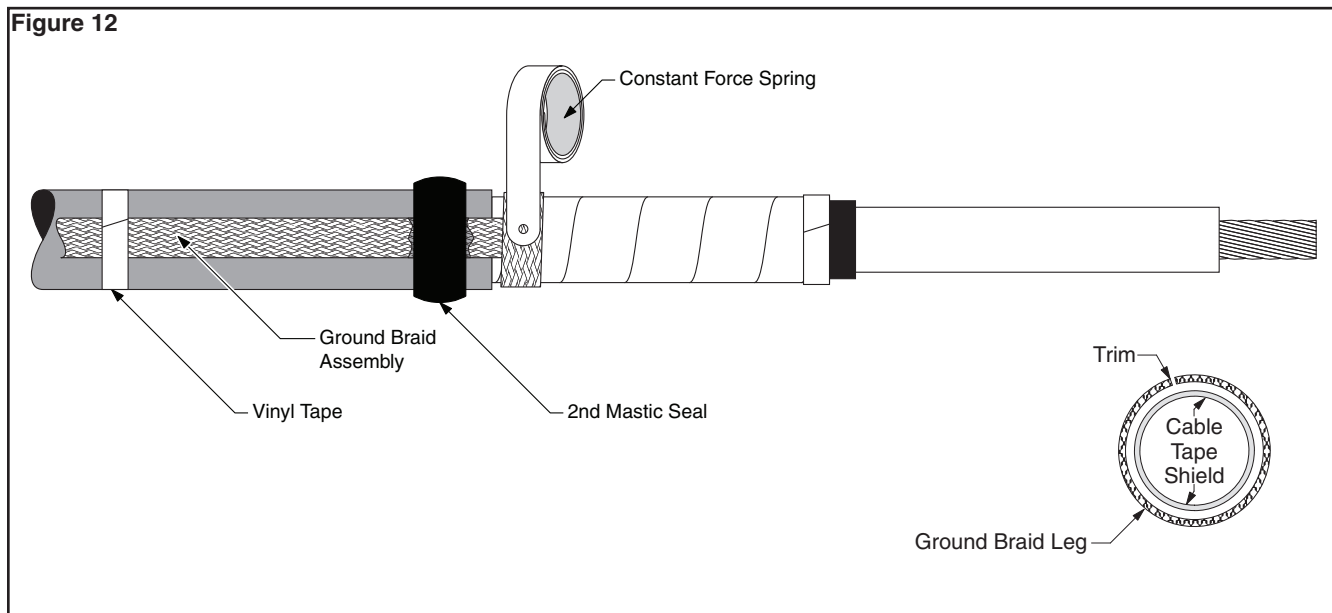

- Wrap two half-lapped layers of vinyl tape around mastic seal, constant force spring and onto tape shield 1/2" (13 mm) (Figure 13).

SPECIAL NOTE FOR CLOTH OR PAPER SEMI-CON INSULATION SHIELD

In cables with cloth or paper semi-conductive shields, it is recommended the shield be overwrapped with one half-lapped layer of highly stretched semi-conductive rubber tape such as Scotch® Electrical Semi-Conducting Tape 13 to keep cable semicon from unwinding.

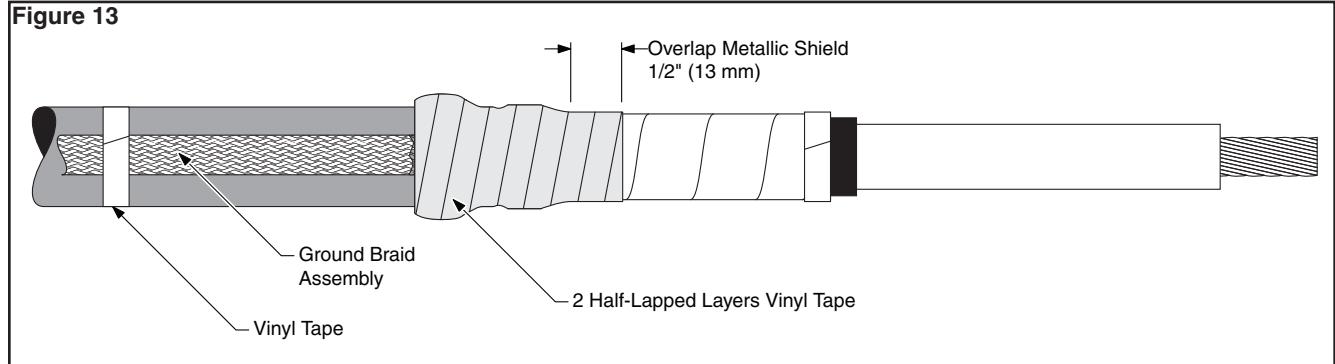

- Install jacket cold shrink tube beginning 1" from end of semi-con (Figure 14). Go to "B. Install Termination", this section.

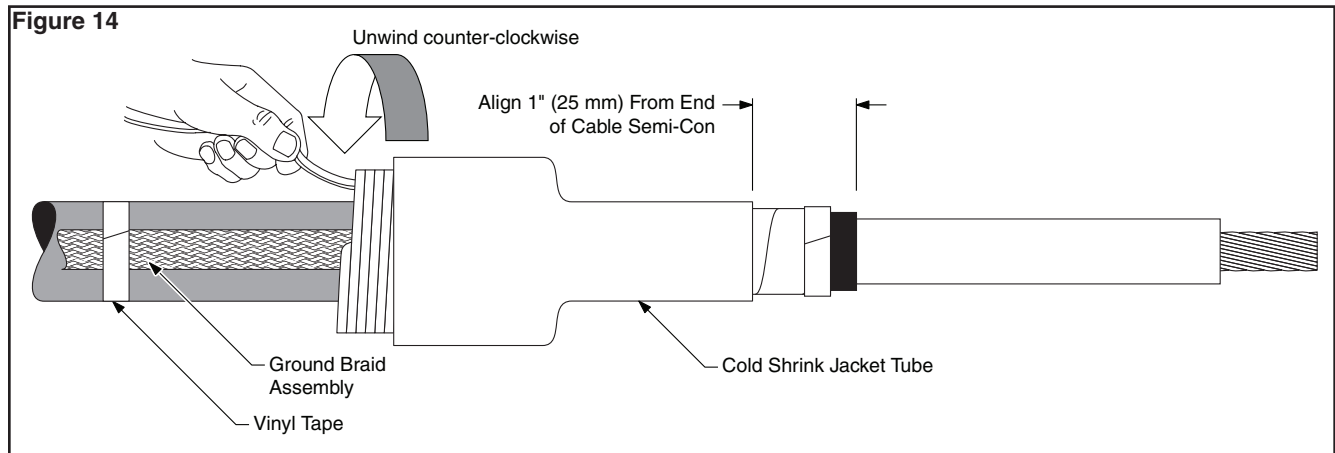

Instructions for Wire Shielded Feeder Cables with Ground Connection

- For wire shield cables, bend leading 6" (150 mm) of exposed shield wires back upon themselves to jacket edge (Figure 15).

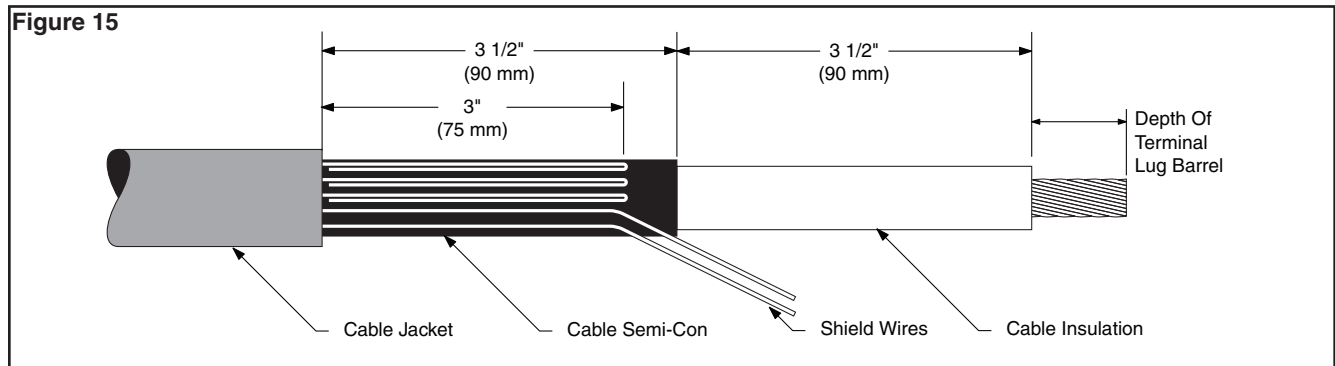

14. Select one mastic strip from kit and remove white release liners. Using light tension, apply a single wrap of mastic around the cable jacket 1/4" (6 mm) from cut edge (Figure 16). Cut off excess.

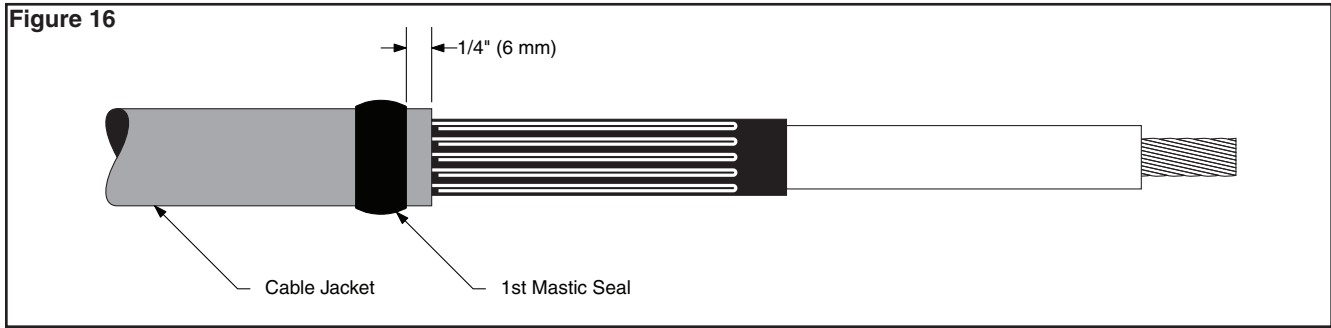

15. Position pre-formed ground braid with short tail over wire shield directly adjacent to cable jacket cut edge. Position long tail of ground braid, extending over cable jacket with solder block over mastic strip (Figure 17). Secure ground braid to cable jacket using vinyl tape at least 2" (50 mm) from edge of cable jacket (Figure 17).

Note: Ground braid, constant force spring and cold shrink jacket tube are in the same bag.

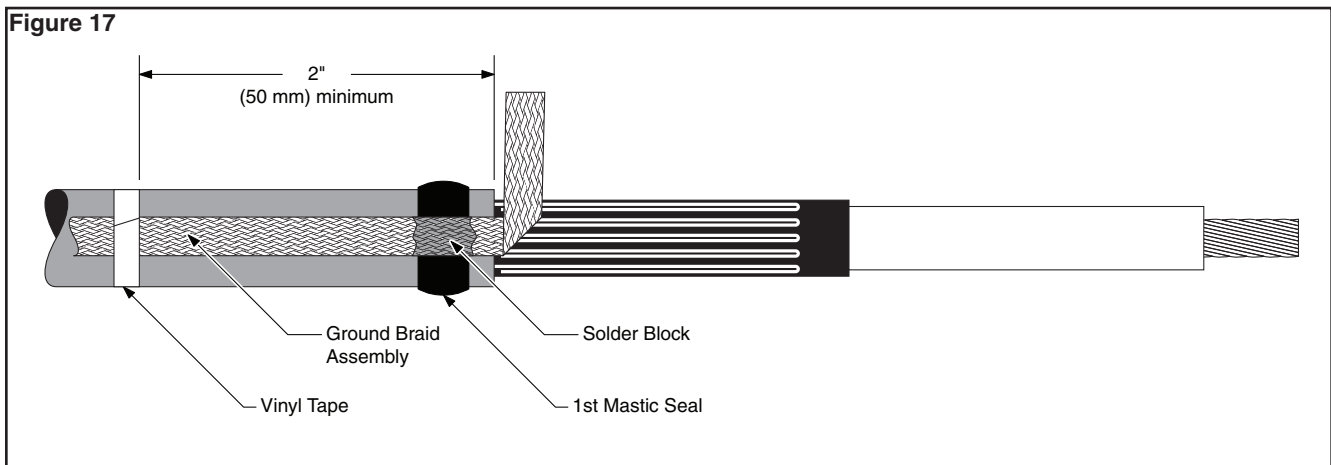

16. Wrap ground braid around cable tape shield wires one complete wrap, trim excess to prevent overlap and secure in place with constant force spring. Wrap spring in same direction as ground braid (Figure 18). Cinch (tighten) the spring after wrapping the final winding.
17. Select second mastic strip from kit and remove white release liners. Apply a second mastic band over solder block on ground braid and previously applied mastic (Figure 18) Cut off excess.

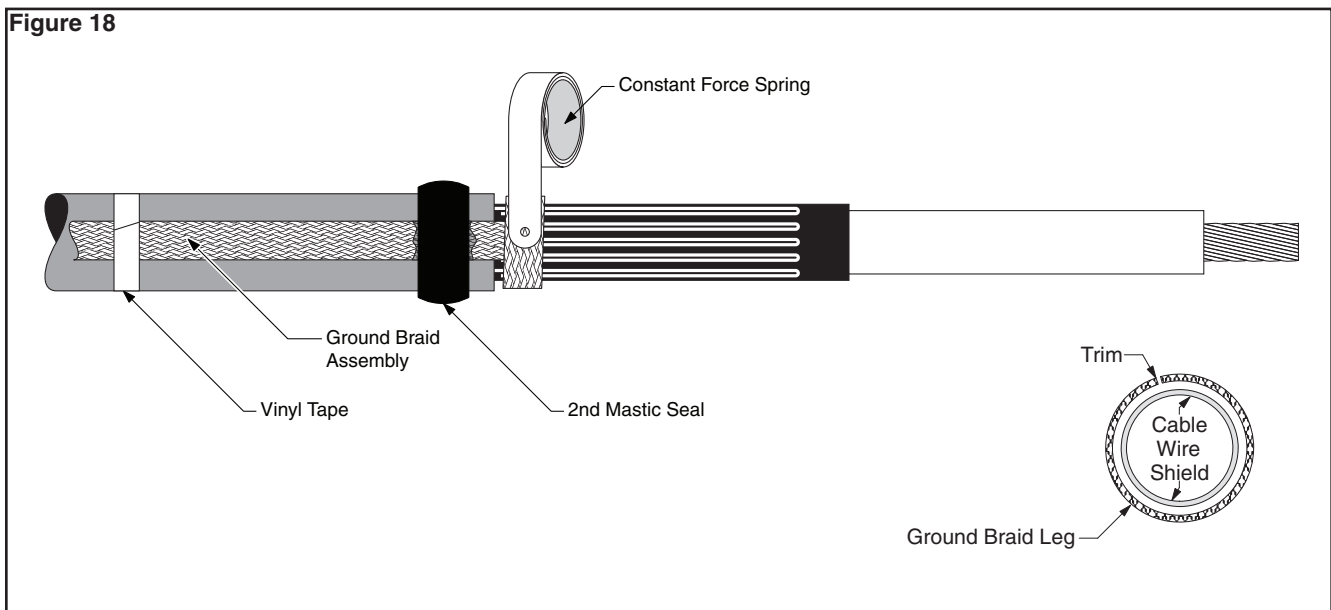

18. Wrap two half-lapped layers of vinyl tape around mastic seal, constant force spring and 1/2" (13 mm) onto shield wires (Figure 19).

SPECIAL NOTE FOR CLOTH OR PAPER SEMI-CON INSULATION SHIELD

In cables with cloth or paper semi-conductive shields, it is recommended the shield be overwrapped with one half-lapped layer of highly stretched semi-conductive rubber tape such as Scotch® Electrical Semi-Conducting Tape 13 to keep cable semicon from unwinding.

Figure 19

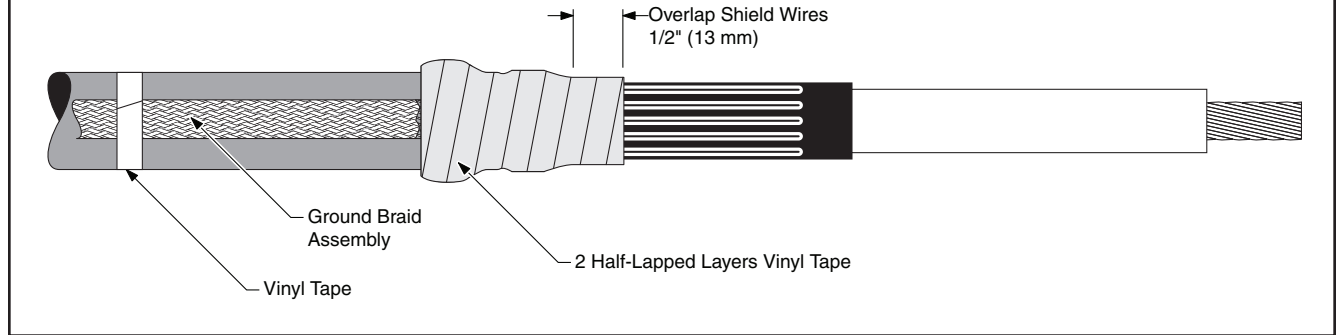

19. Install Cold Shrink jacket tube beginning 1" (25 mm) from end of semi-con (Figure 20). Go to "B. Install Termination", this section.

Figure 20

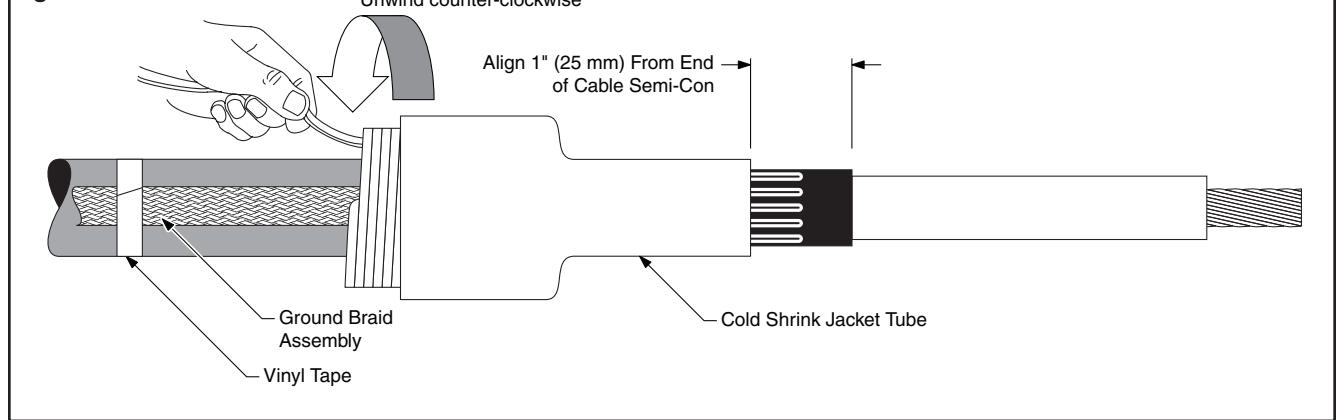

Instructions for UniShield® Feeder Cables With Ground Connection

20. Prepare cable using dimensions shown in Figure 21. Be sure to allow for depth of terminal lug. Pull shield wires through semi-conductive jacket to leading edge of constant force spring (Figure 21).

Figure 21

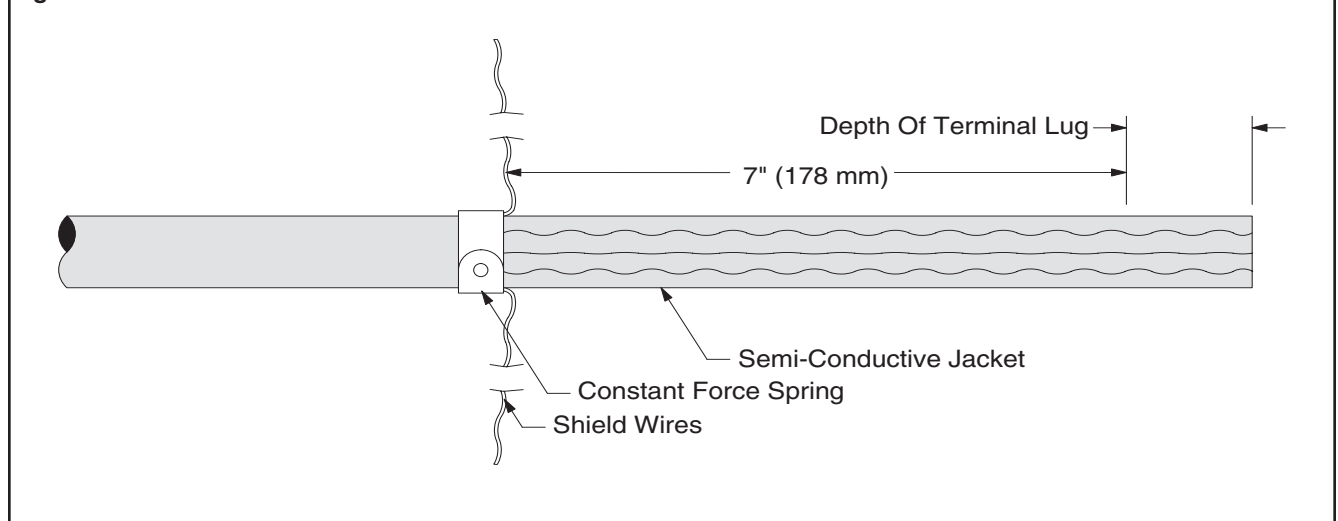

21. Remove constant force spring. Bend shield wires back upon cable jacket 3" (76 mm). Cut excess shield wire and discard (Figure 22).

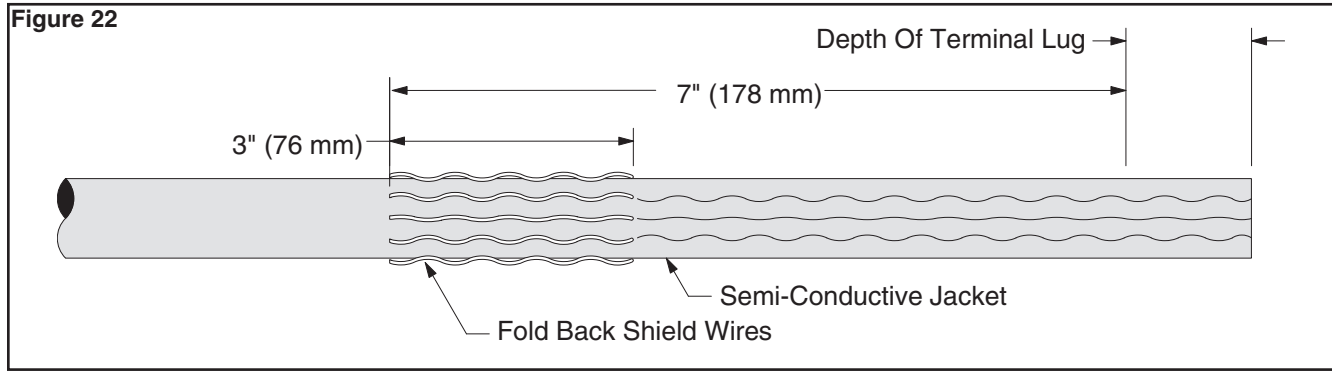

22. Remove semi-conductive jacket to dimension shown in Figure 23.

Note: To ease jacket removal, install constant force spring as shown in Figure 23 and ring cut 80% through jacket. Remove jacket section by pulling against constant force spring. DO NOT BELL SEMI-CON JACKET. Remove constant force spring.

Some UniShield® cables feature dual-layer semi-conductive jackets. Both layers must be removed during cable preparation.

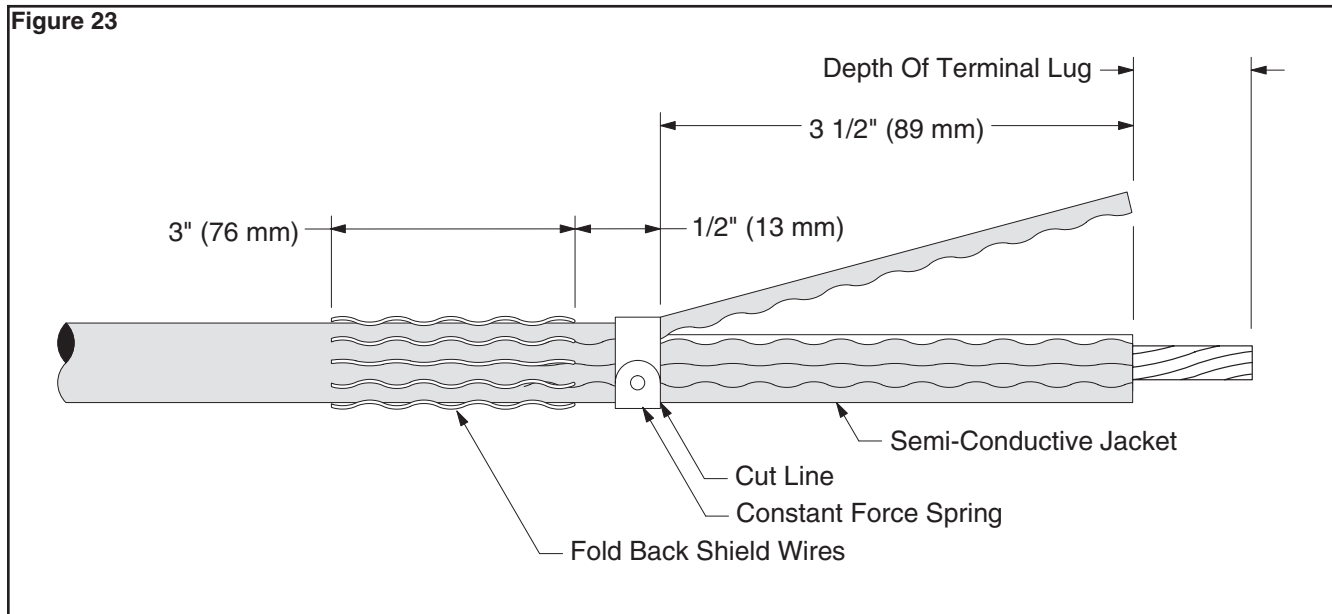

23. Select one mastic strip from kit and remove white release liners. Using light tension, apply a single wrap of mastic around the cable jacket 1/4" (6 mm) from shield wires (Figure 24). Cut off excess.

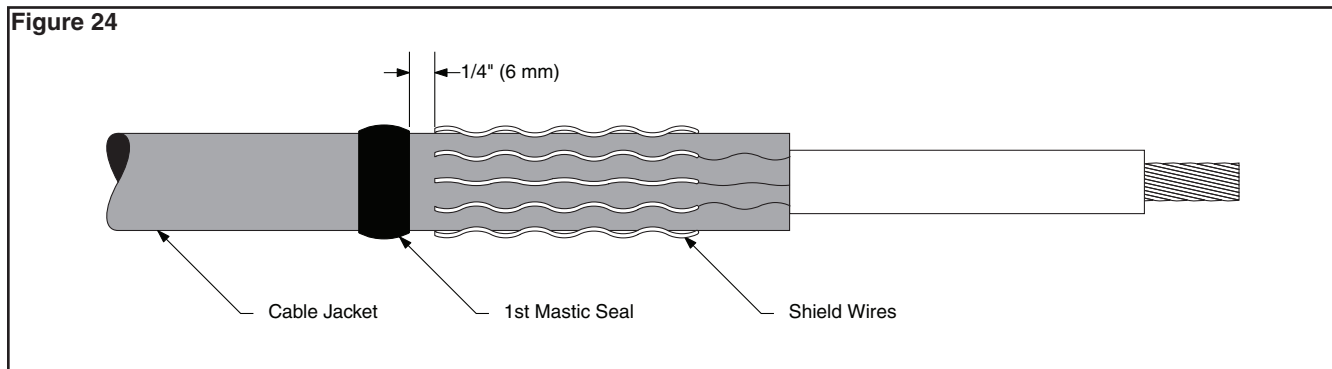

24. Position pre-formed ground braid with short tail directly over cut edge of folded back shield wires. Position long tail of ground braid, extending over cable semi-conductive jacket with solder block over mastic strip (Figure 25). Secure ground braid to cable jacket using vinyl tape at least 2" (50 mm) from end of shield wires (Figure 25).

Note: Ground braid, constant force spring and cold shrink jacket tube are in the same bag.

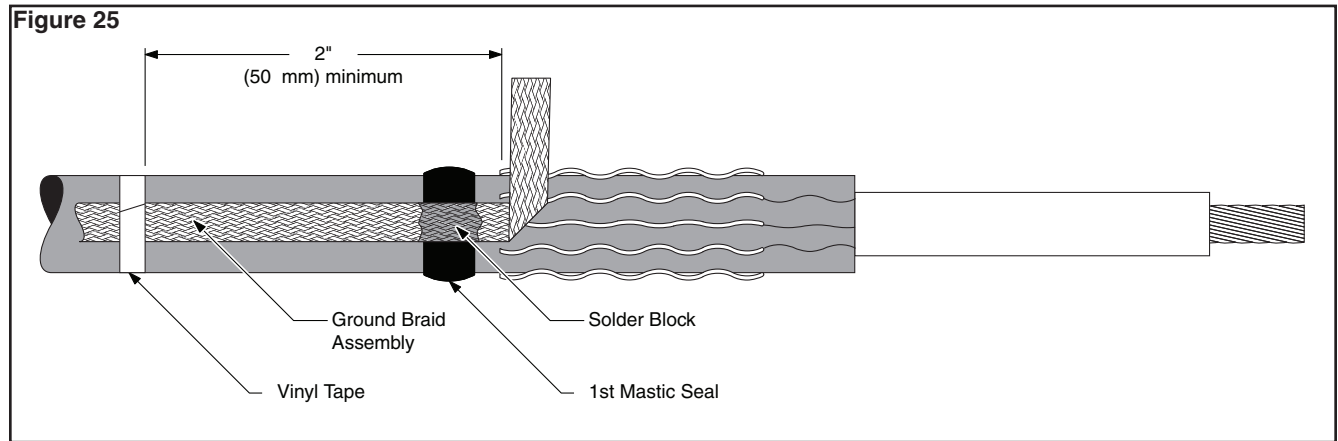

25. Wrap ground braid around cable shield wires one complete wrap, trim excess to prevent overlap and secure in place with constant force spring. Wrap spring in same direction as ground braid (Figure 26). Cinch (tighten) the spring after wrapping the final winding.
26. Select second mastic strip from kit and remove white release liners. Apply a second mastic band over solder block on ground braid and previously applied mastic (Figure 26) Cut off excess.

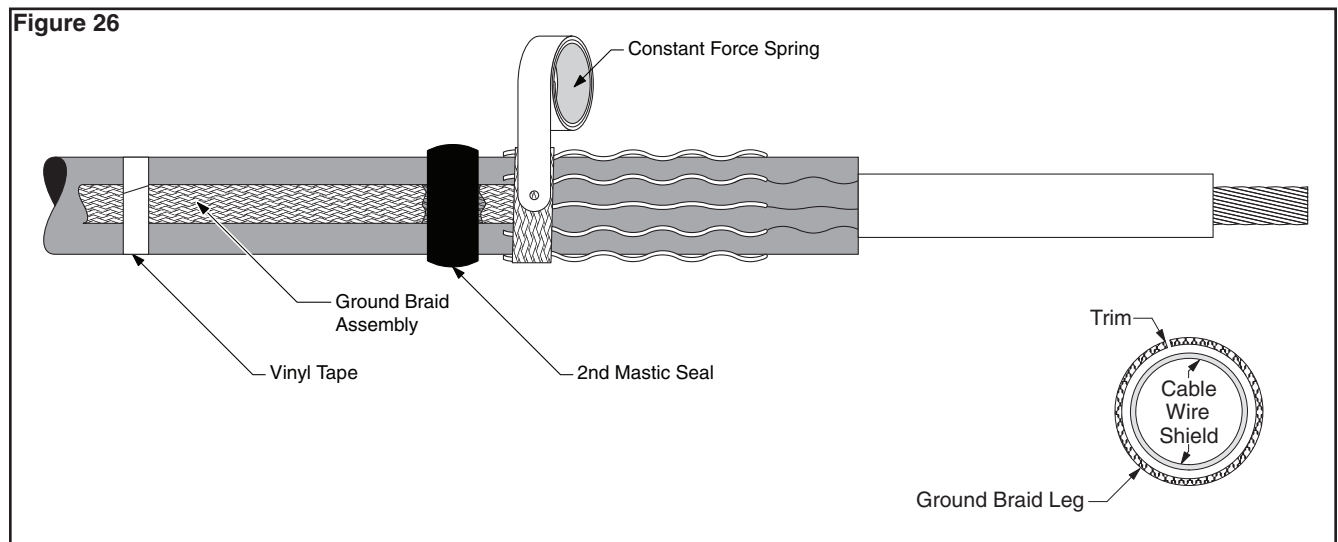

27. Wrap two half-lapped layers of vinyl tape around mastic seal, constant force spring and 1/2" (13 mm) onto exposed shield wires (Figure 27).

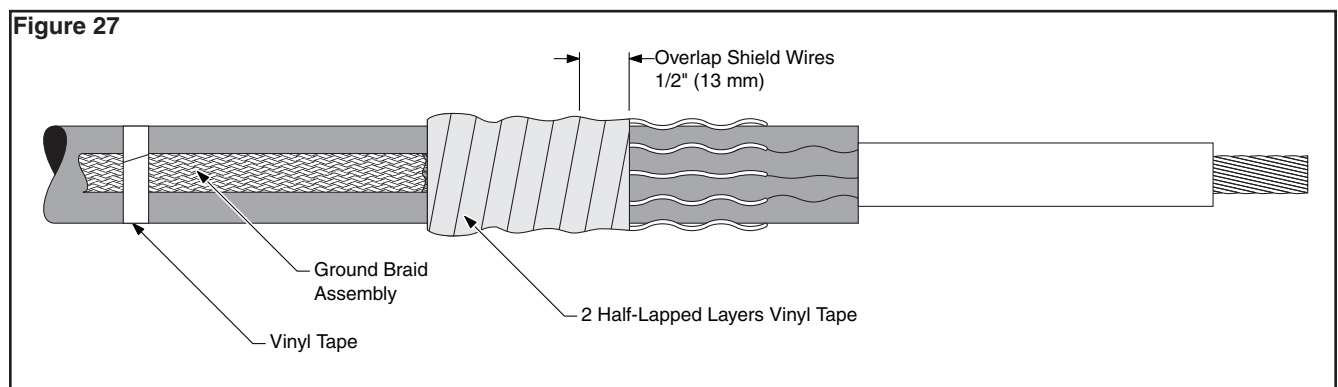

28. Install Cold Shrink jacket tube beginning 1" (25 mm) from end of semi-con (Figure 28).

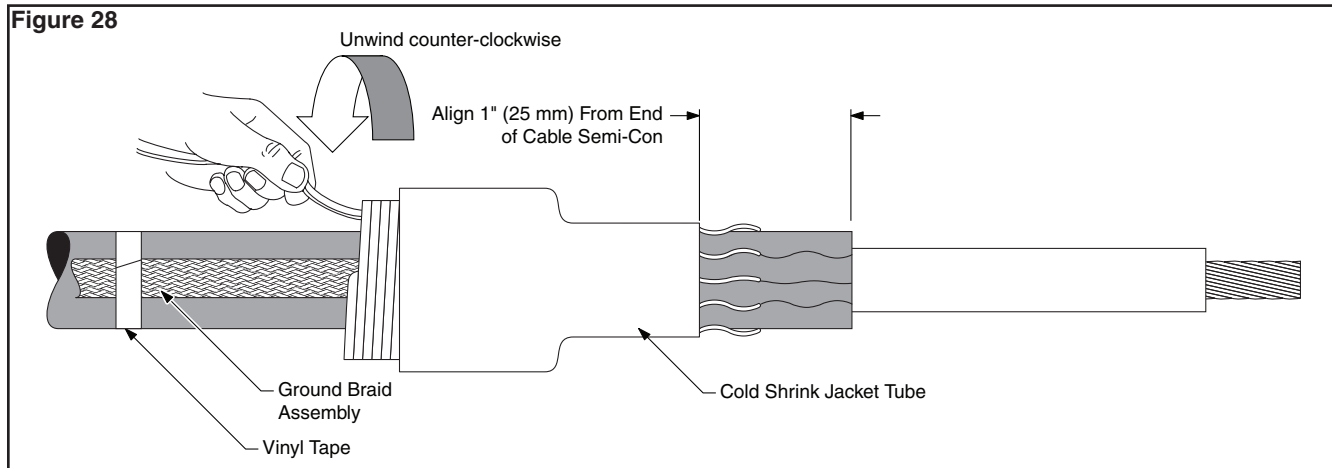

Instructions for 5/8 kV Pigtail Shielded Feeder Cables with Ground (Ribbon, Wire Shielded or UniShield® Cables)

B. Install Termination

1. Install silicone grease at semi-con step and on cable insulation.

Note: Termination is in bag with copper tape strip.

2. Install termination beginning at jacket tube edge (Figure 29).

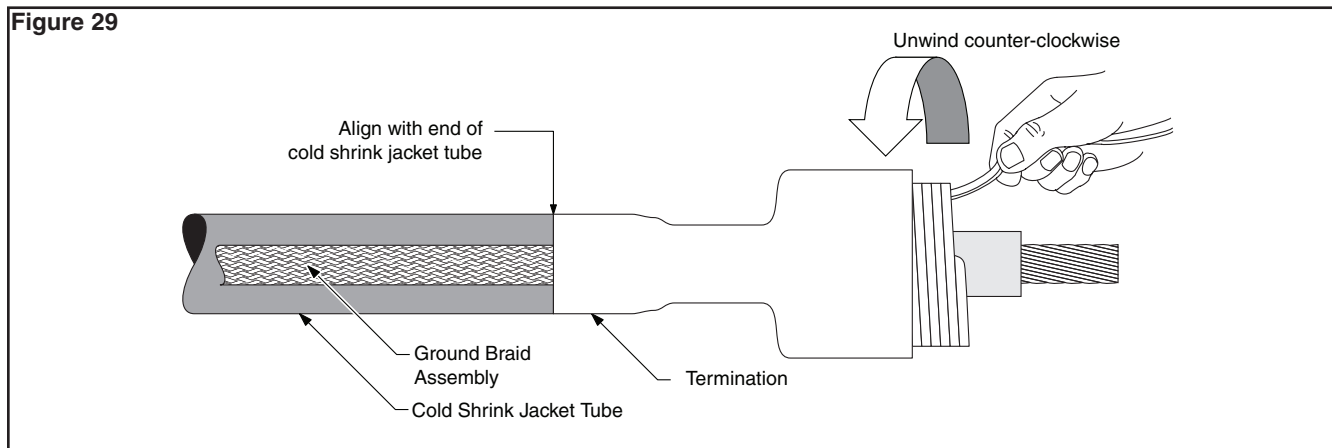

C. Install Lugs

1. Install and crimp lugs per manufacturer's direction; see back page if 3M™ Lugs are used.

2. Bolt lugs together. See Table 1 on cover for maximum bolt length. See Figure 30 for proper bolt/lug arrangement.

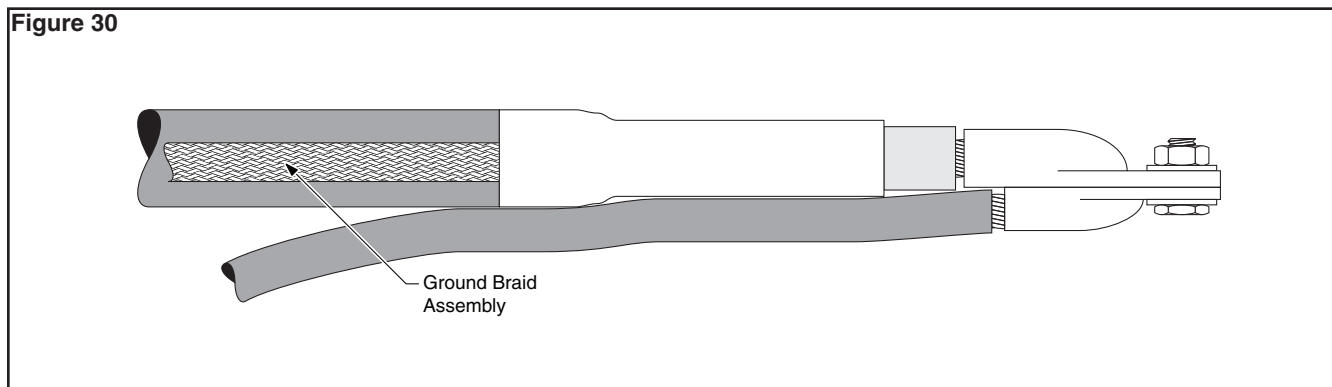

D. Install Lug Cover

1. Separate cables and apply mastic strip between and around them, centered over jacketing tube and termination (Figure 31). Mastic will be on end of termination and cold shrink jacketing tube. Build mastic to an overall diameter that is greater than the inside diameter of the Lug Cover. Press cables together and make certain that no void exists between them (Figure 31).

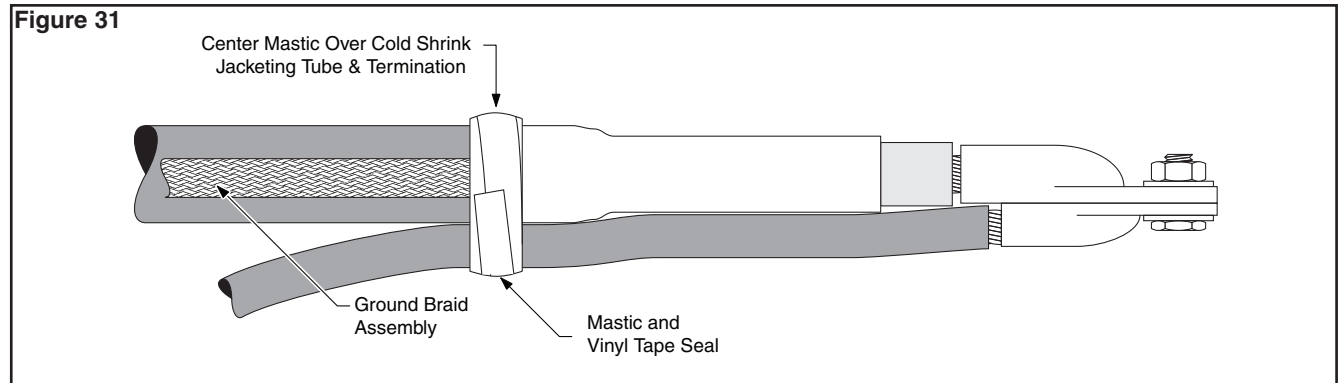

2. Overwrap the mastic with 1 or 2 wraps of vinyl tape (Figure 31).
3. Install Lug Cover. Position Lug Cover so the punched holes are positioned between the cables (Figure 32).

Note: The kit contains a small tube of Silicone Grease. Use it to lightly lubricate the mastic and vinyl tape wraps. This will aid in the installation of the Lug Cover.

4. Be sure that the punched holes are beyond the cable end of the mastic and vinyl tape wrap. Insert the cable tie through the holes (Figure 32).

Hint: Inserting the cable tie from the back side of the Lug Cover will aid in visually aligning the cable tie through both holes.

5. Tighten the cable tie. Cut off excess length only if necessary. Cable ties are reusable.

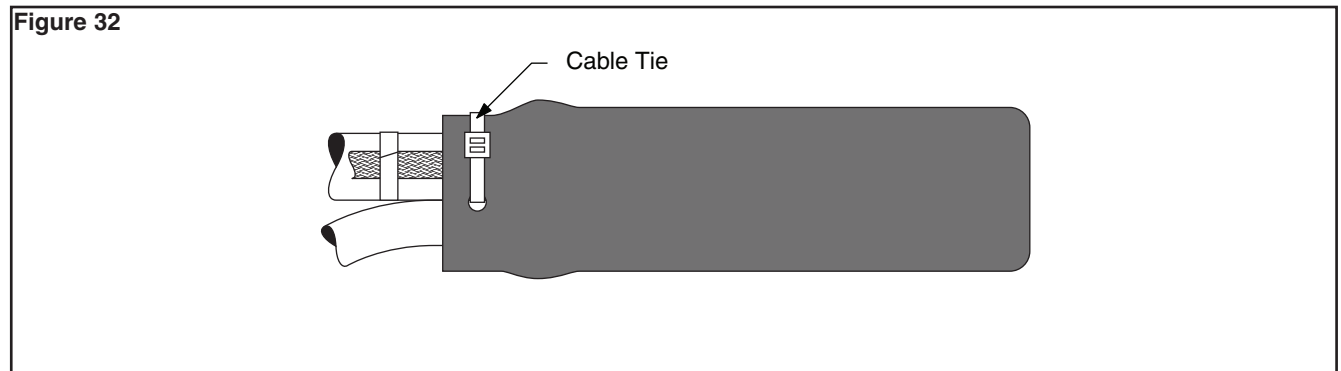

Tooling Index

Lug and Crimping Information for 3M™ Scotchlok™ Copper Lugs	
30014 through 30045 One hole	31145 through 31166 Two hole

Copper Lugs

Cable Size	Stud Size	3M™ Scotchlok™ Copper Lug Number	CRIMPING TOOL-DIE SETS (NUMBER OF CRIMPS)							
			Burdny Corporation				Thomas & Betts Corporation			Square D Co. Anderson Div.
			MD6	MY29	Y34A	Y35, Y39, Y45*, Y46*	TBM 5	TBM 8	TBM 15	VC6-3 VC6-FT**
6	10 1/4 5/16	30014 30015 30016		6 AWG (1)		U5CRT (1)	Blue (1)	Blue (1)		Universal (1)
4	10 1/4 3/8	30018 30019 30021	W161 (1)	4 AWG (1)	A4CR (1)	U4CRT (1)	Grey (1)	Grey (1)		Universal (1)
2	1/4 5/16 3/8	30022 30023 30024	W162 (2)	2 AWG (1)	A2CR (1)	U2CRT (2)	Brown (1)	Brown (1)	33 (1)	Universal (2)
1	5/16 3/8	30027 30028		1 AWG (1)	A1CR (1)	U1CRT (2)	Green (1)	Green (1)	37 (1)	Universal (2)
1/0	5/16 3/8	30031 30032	W163 (2)	1/0 (1)	A25R (1)	U25RT (1)	Pink (2)	Pink (2)	42H (2)	Universal (1)
2/0	3/8	30036	W241 (2)	2/0 (1)	A26R (1)	U26RT (2)	Black (2)	Black (2)	45 (1)	Universal (1)
3/0	1/2	30041	W243 (2)	3/0 (1)	A27R (1)	U27RT (2)	Orange (2)	Orange (2)	50 (1)	Universal (2)
4/0	1/2	30045 31145	BG (3) BG (4)	4/0 (1) 4/0 (2)		U28RT (3) U28RT (2)	Purple (2) Purple (3)	Purple (2) Purple (3)	54H (2) 54H (3)	Universal (2) Universal (3)
250	1/2	31149	W166 (4)	250 (2)	A29R (2)	U29RT (3)	Yellow (2)	Yellow (2)	62 (2)	Universal (2)
300	1/2	31153			A30R (2)	U30RT (3)		White (3)	66 (3)	Universal (3)
350	1/2	31156			A31R (2)	U31RT (3)		Red (4)	71H (4)	
400	1/2	31160			A32R (2)	U32RT (3)		Blue (4)	76H (4)	
500	1/2	31166			A34R (2)	U34RT (3)		Brown (4)	87H (4)	

*Y45 and Y46 accept all Y35 dies ("U" series). For Y45 use PT6515 adapter. For Y46 use PUADP adapter.

**Anderson VC6-3 and VC6-FT require no die set.

3M, Scotch and Scotchlok are trademarks of 3M Company. UniShield is a trademark of General Cable Technologies, Inc.

Important Notice

All statements, technical information, and recommendations related to 3M's products are based on information believed to be reliable, but the accuracy or completeness is not guaranteed. Before using this product, you must evaluate it and determine if it is suitable for your intended application. You assume all risks and liability associated with such use. Any statements related to the product which are not contained in 3M's current publications, or any contrary statements contained on your purchase order shall have no force or effect unless expressly agreed upon, in writing, by an authorized officer of 3M.

Warranty; Limited Remedy; Limited Liability.

This product will be free from defects in material and manufacture for a period of one (1) year from the time of purchase. **3M MAKES NO OTHER WARRANTIES INCLUDING, BUT NOT LIMITED TO, ANY IMPLIED WARRANTY OF MERCHANTABILITY OR FITNESS FOR A PARTICULAR PURPOSE.** If this product is defective within the warranty period stated above, your exclusive remedy shall be, at 3M's option, to replace or repair the 3M product or refund the purchase price of the 3M product. **Except where prohibited by law, 3M will not be liable for any indirect, special, incidental or consequential loss or damage arising from this 3M product, regardless of the legal theory asserted.**

3M™ Scotchlok™ connectors and tools are engineered to work together to achieve consistently superior performance in the field. Tools from other manufacturers may not meet the tight quality tolerances of 3M tools and can damage the crimping and performance of a 3M connector. Therefore, the published 3M warranty does not extend to any 3M connectors crimped in tools not made by 3M. The warranty on 3M Scotchlok splicing tools can also be voided if used on non-3M connectors.



Electrical Markets Division

6801 River Place Blvd.
Austin, TX 78726-9000
800-626-8381
Fax 800-828-9329
www.3M.com/electrical



Recycled paper
40% Pre-consumer waste paper
10% Post-consumer waste paper

Litho in USA
© 3M 2005 78-8126-9102-6-B