

Lighting Controls

DATE: _____ LOCATION: _____

TYPE: _____ PROJECT: _____

CATALOG #: _____

OMNI® LINE VOLTAGE ULTRASONIC & PIR CEILING SENSOR CEILING MOUNT OCCUPANCY SENSORS

FEATURES

- IntelliDAPT® self-adaptive technology - no manual adjustment required
- All-digital Dual Technology (Ultrasonic (US) and Passive Infrared (PIR) sensor)
- Non-volatile memory for sensor settings
- 500–2,000 square-foot coverage area (depending on model)
- Self-contained power supply
- Universal voltage (100-277VAC; 50/60 Hz)
- UL and cUL listed
- Five-year warranty



SPECIFICATIONS

CONSTRUCTION

- Casing- rugged, high-impact, injection-molded plastic KJB ABS
- Cicolac (UL-945VA) flame class rating, UV inhibitors
- Color-coded leads are 6" long (152.4 mm)
- 8.2 oz (232g)
- Off-white
- Red - ultrasonic detection
- Green - ultrasonic motion
- Dual-element pyrometer and 12-element cylindrical rugged lens

MOUNTING

- Mounting using a 3 inch (76.2mm) mud ring attached to 4 inch (101.6mm) square electrical box
- Recommended MAX mounting height: 12ft. (3.66m)

ELECTRICAL

- OMNIDT500: 40kHz output
- OMNIDT1000 and OMNIDT2000: 32kHz
- 100–277VAC; 50/60Hz
- 20A: 120VAC Incandescent
- 20A: 120 or 277VAC Magnetic Ballast
- 16A: 120 or 277VAC Electronic Ballast
- 1HP: 120VAC Motor Load
- 1HP: 277VAC Motor Load

OPERATIONS

- IntelliDAPT
 - Auto reset from test setting
 - Self-adjusting timer
 - Self-adjusting ultrasonic and passive infrared thresholds

OPERATIONS (CONTINUED)

- Automatic false-ON/false-OFF corrections
- Timer Settings
 - Automatic mode: 8–30 min. (self-adjusts based on occupancy)
 - Test mode: 8 seconds (for an easy check at installation)
- Coverage
 - 500–2,000 square feet (depending on model) coverage

OPERATING ENVIRONMENT

- Indoor use only
- Operating temperature: 32° to 104°F (0° to 40°C)
- Relative humidity (non-condensing): 0% to 95%

CERTIFICATIONS

- UL and cUL listed

WARRANTY

- 5 year warranty

ORDERING GUIDE

Example: OMNIDT500BP1277

CATALOG #

Series

- OMNIDT500BP1277 Line Voltage Ultrasonic and PIR Ceiling Sensor 500 sq. ft. coverage
- OMNIDT1000BP1277 Line Voltage Ultrasonic and PIR Ceiling Sensor 1000 sq. ft. coverage
- OMNIDT2000BP1277 Line Voltage Ultrasonic and PIR Ceiling Sensor 2000 sq. ft. coverage

Lighting Controls

OMNI[®] LINE VOLTAGE ULTRASONIC & PIR CEILING SENSOR

CEILING MOUNT OCCUPANCY SENSORS

DIMENSIONS

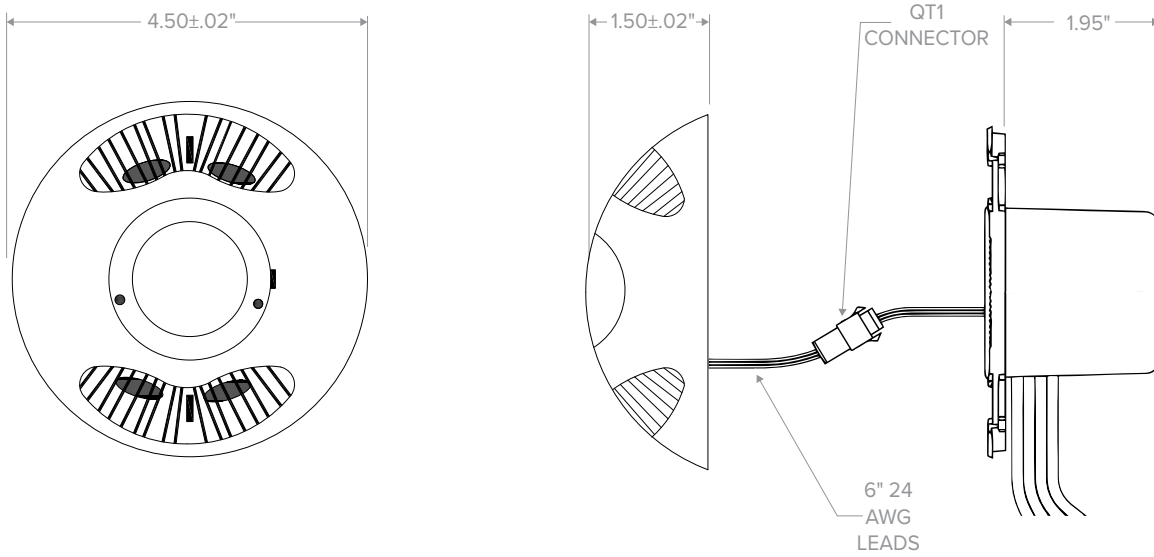

ADDITIONAL INFORMATION

Coverage Patterns

DT 500 Range

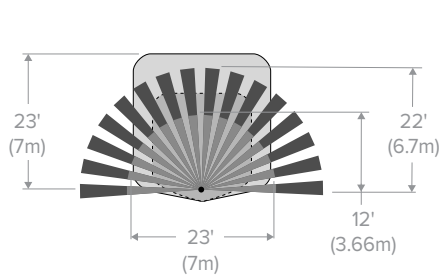

- US Minor Motion
- US Major Motion
- IR Minor Motion
- IR Major Motion

DT 1000 Range

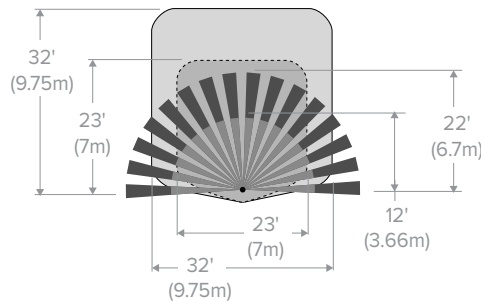

- US Minor Motion
- US Major Motion
- IR Minor Motion
- IR Major Motion

DT 2000 Range

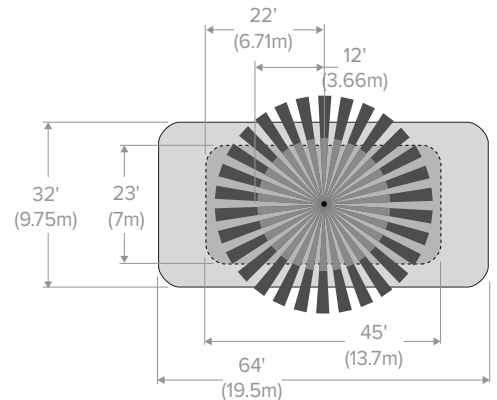

- US Minor Motion
- US Major Motion
- IR Minor Motion
- IR Major Motion

Lighting Controls

OMNI[®] LINE VOLTAGE ULTRASONIC & PIR CEILING SENSOR

CEILING MOUNT OCCUPANCY SENSORS

ADDITIONAL INFORMATION

Wiring Diagrams

