

L36
Padlocking Handle Kit

Installation Instruction For Single-Point Padlocking Handle Kit
Catalog Number: AL36A

1. Locate and drill holes for the handle as shown. Do not drill holes for the rod guides.
2. Select latch the rod stop for correct handle rotation. Assemble the handle parts and the latch stop as shown.

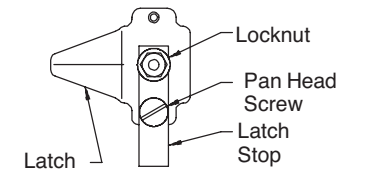

Installation Instruction For Three-Point Padlocking Handle Kit
Catalog Numbers: AL36BR, AL36CR, AL36DR

1. Locate and drill the holes in the door from the outside edges using dimensions shown.
2. Select latch the rod stop for the correct handle rotation and install the latch kit as shown. Install the handle gasket on the outside of the door to obtain proper sealing. Latch rods are made to fit different size enclosures. If the latch rod(s) is too long, select the proper hole and cut the latch rods approximately 3/8 inch from the center of the desired hole as shown in detail "A". Be certain of the hole selection before cutting. Place roller pin in the hole shown and secure with the retaining ring. If the gasket compression is too great, simply move the roller one hole at a time until proper gasket compression is attained. Position spacers for the proper location of the latch. Three large washers are provided so the position of the latch can be adjusted by spacing it in or out as required.

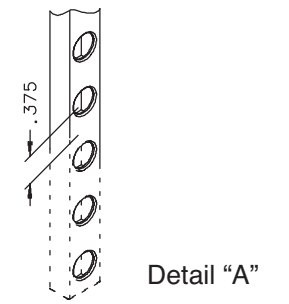

WARNING

To avoid electric shock, do not energize any circuits before all internal and external electrical and mechanical clearances are checked to assure that all assembled equipment functions safely and properly.

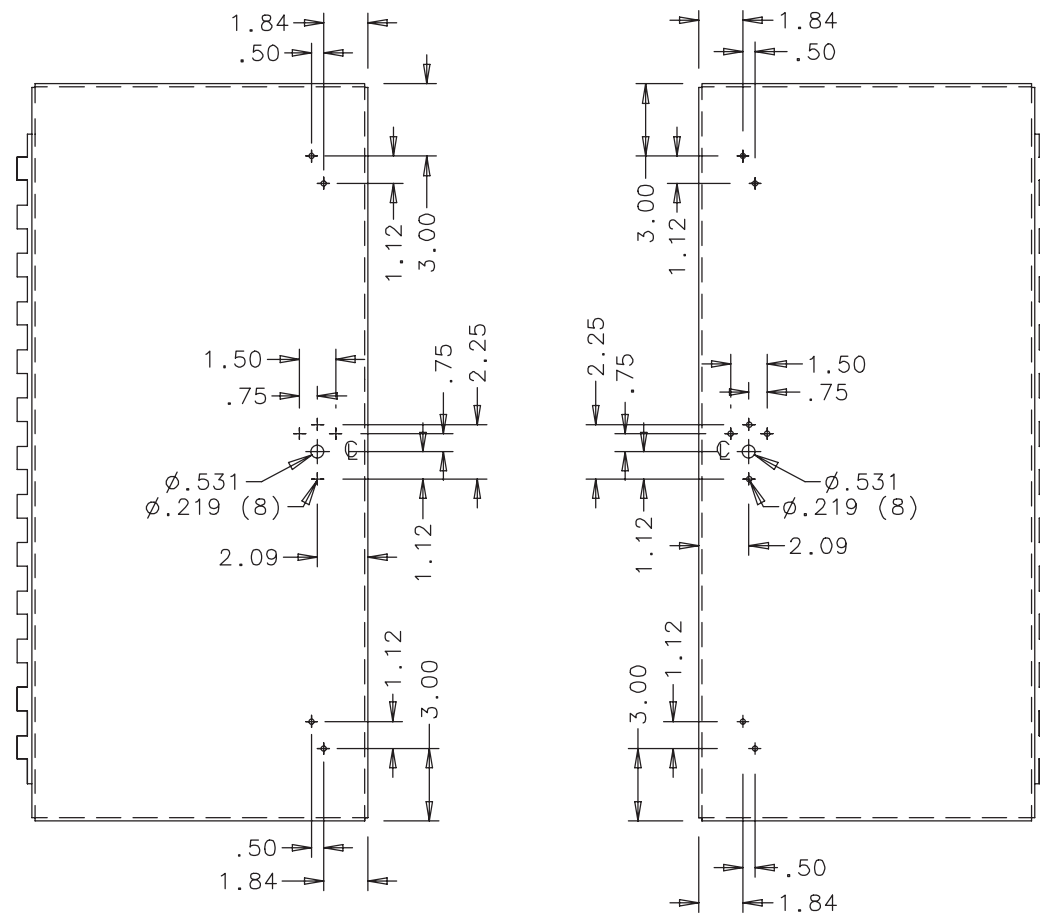

Door Hinged On Left

Door Hinged On Right

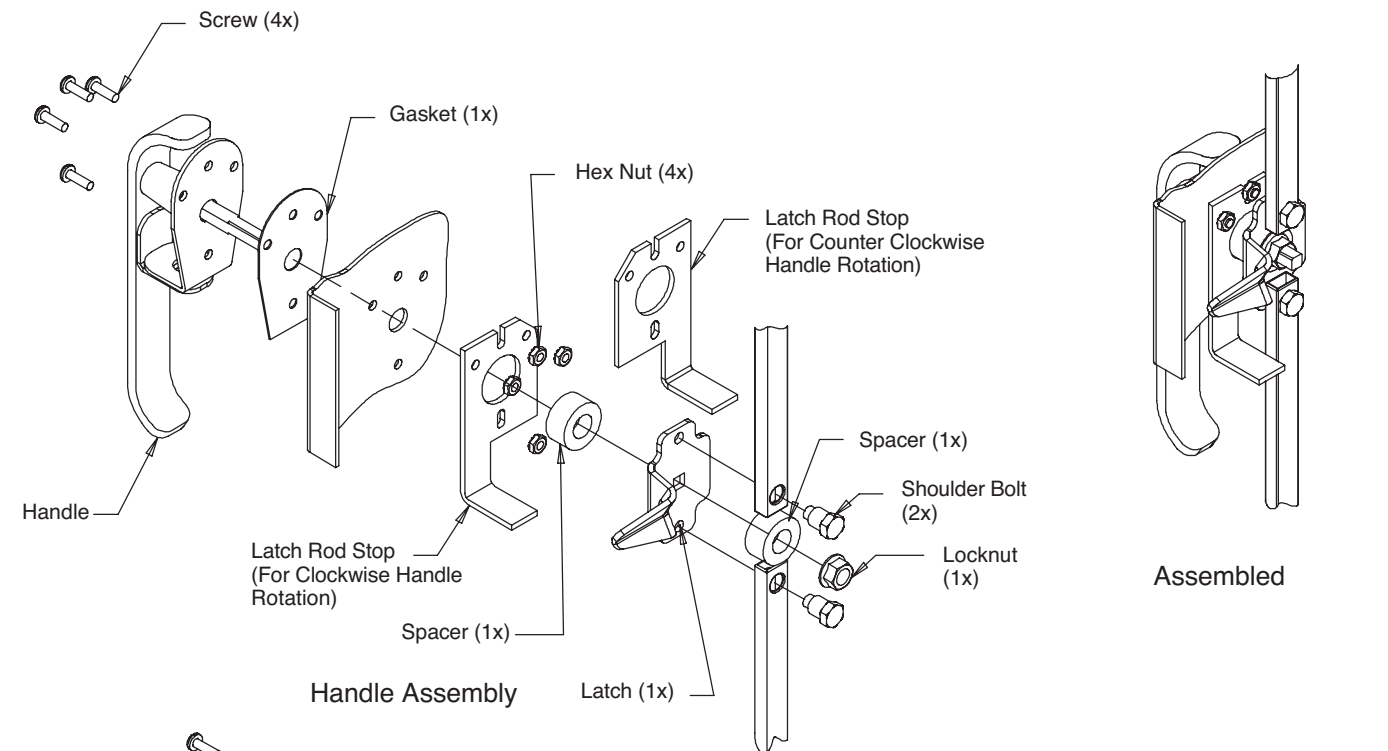

Assembled

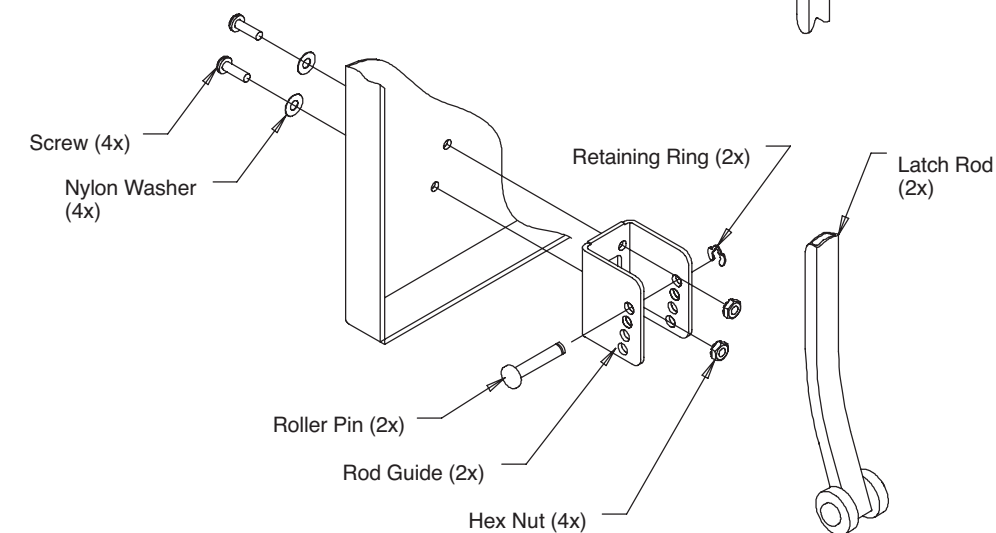

Latch Rod Assembly
(Top and Bottom of Door)

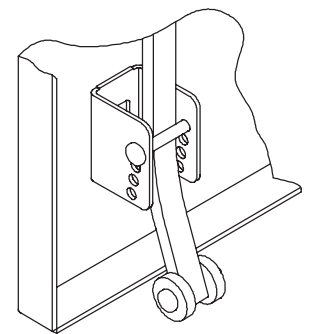

Assembled