

Installation and Operating Instructions

Supension System

SYSPEND 281-MAX



Application examples

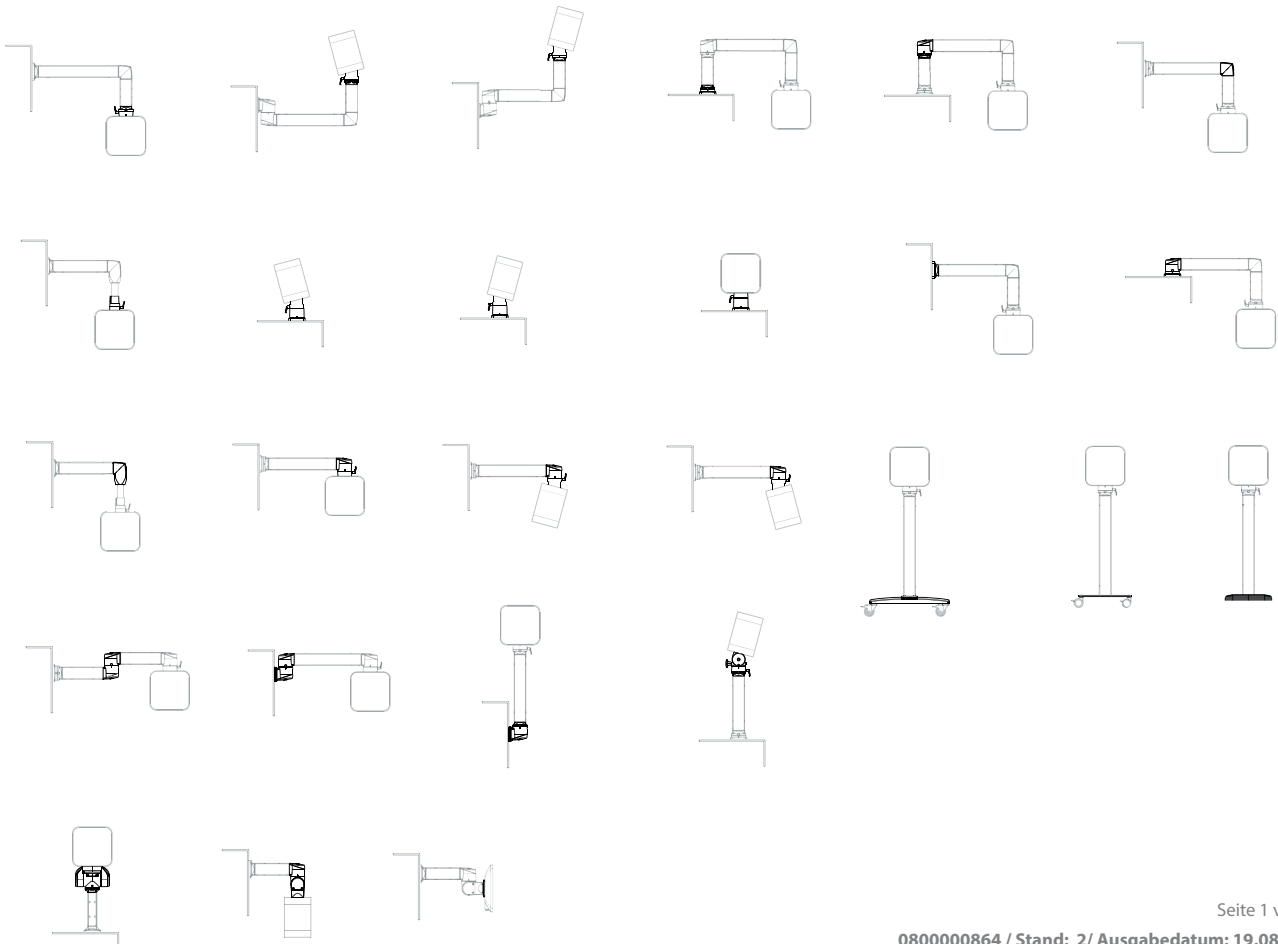

Contents

1. Layout and use of the instructions
2. Safety instructions
3. Mounting of tube
 - 3.1. Round tube
 - 3.2. Vertical
 - 3.3. Horizontal
4. Tube alignment
 - 4.1. Vertical
 - 4.2. Horizontal Option 1
 - 4.3. Horizontal Option 2
5. To ascertain the lever screw in
6. Fine adjustment of the tightness
7. Attitude of the tightness of torque (M)
 - 7.1 Attitude of the tightness of torque (M) Turn/ tilt coupling
8. Fixing at enclosure
 - 8.1. Standard
 - 8.2 Turn/tilt coupling W
 - 8.3 Turn/tilt coupling S
 - 8.4 with adapter plate VESA 75/100
9. Mounting on building or machine
 - 9.1. Standard
 - 9.2. with small base
 - 9.3 with FLEX.base
10. To crew link cap
11. Accessories
12. Accessories for bases
13. Mechanical Data
14. Load diagram SYSPEND 281-MAX
15. Tube Cutoff

1 Layout and use of the instructions

All components that are not included in the delivery specification are shown in grey. The instructions do not necessarily follow the operating or installation sequence. Not all sections apply to every component.

Procedure:

- Identify the pictogram applicable for your application
- Start at the beginning and select the section applicable for your application, select the section by assigning the pictograms

2 Safety Instructions



Risk of injury

Caution ► Do not reach into tubes

3 Mounting of tube

3.1 Round tube

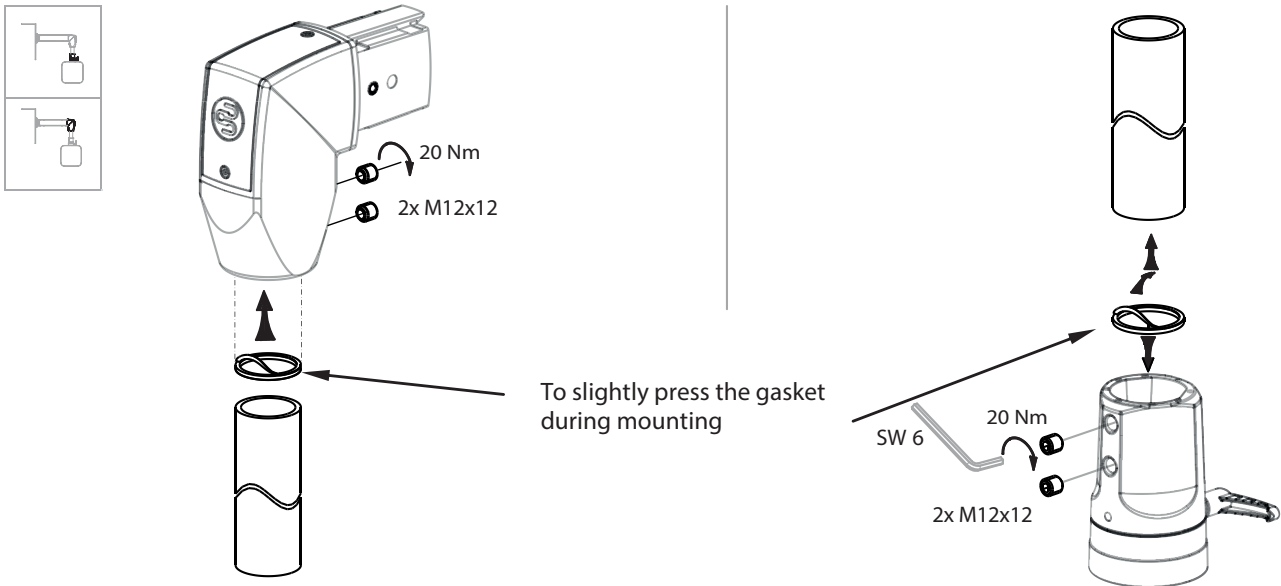

3.2 Vertical

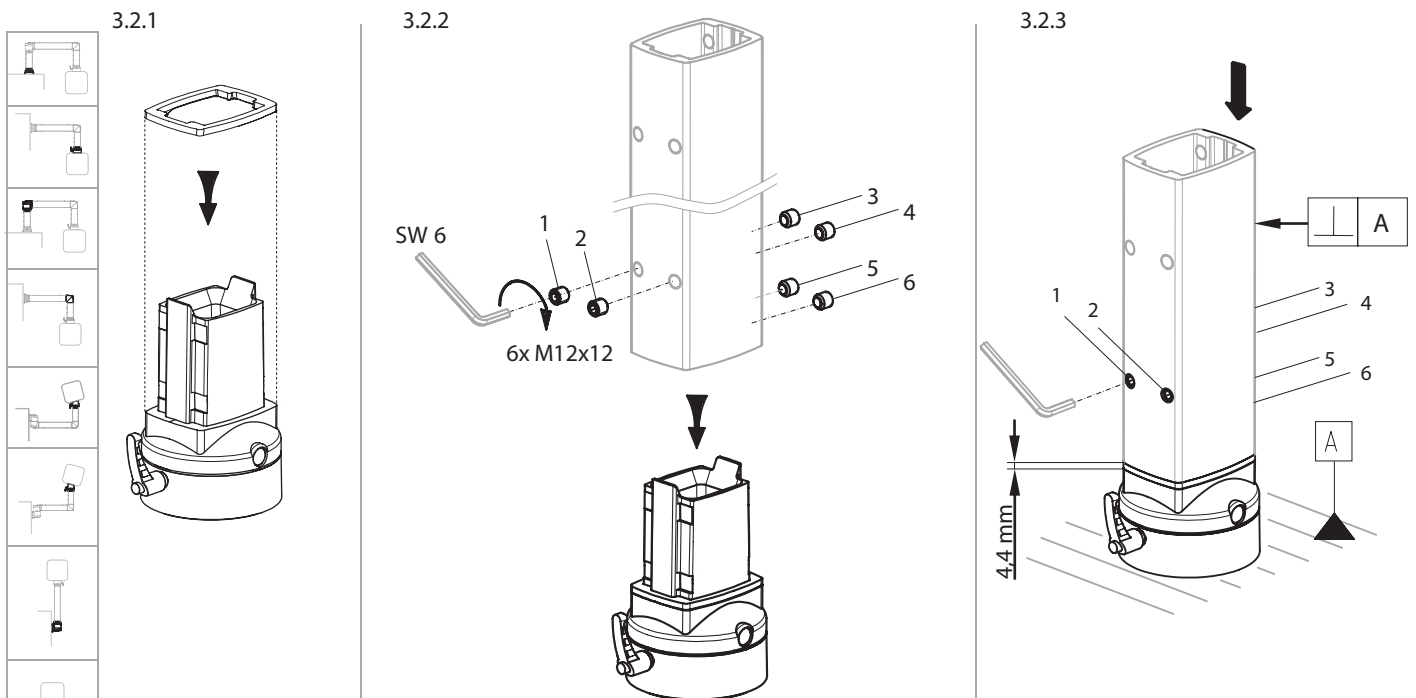

- 3.2.1 - Press gasket flat
- 3.2.2 - Tighten screws 1 – 6 until they are flush on the inside
 - Fit tube in position
- 3.2.3 - Press gasket with tube in axial direction while tightening screw 3 and 4 until there is no play
 - Maintain pressure while tightening screws 5 and 6 to 20 Nm
 - Align tube: see "Tube Alignment"
 - Firmly tighten screws in stages
 - Check that gap is max. 4.4 mm

3.3 Horizontal

3.3.1

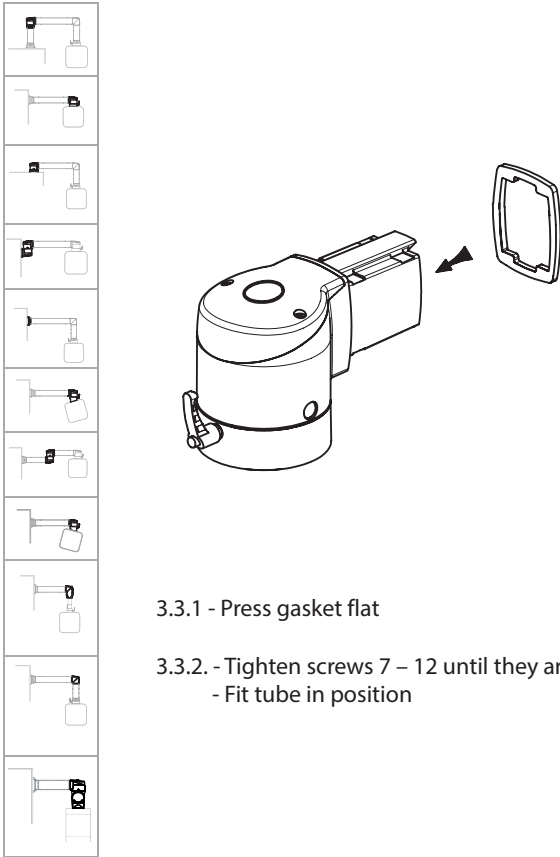

3.3.1 - Press gasket flat

3.3.2

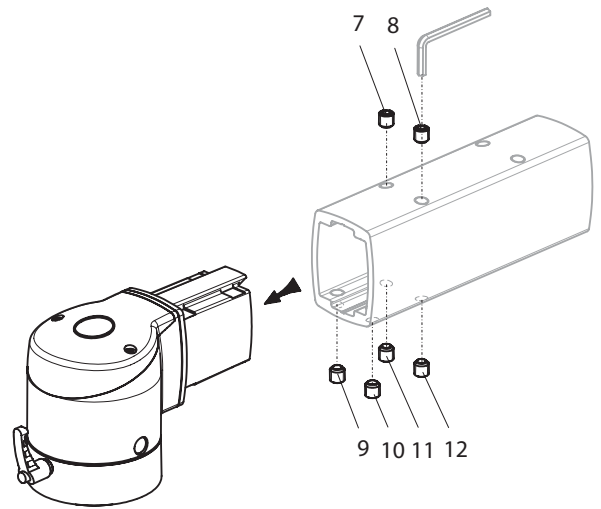

3.3.2 - Tighten screws 7 – 12 until they are
- Fit tube in position

3.3.3

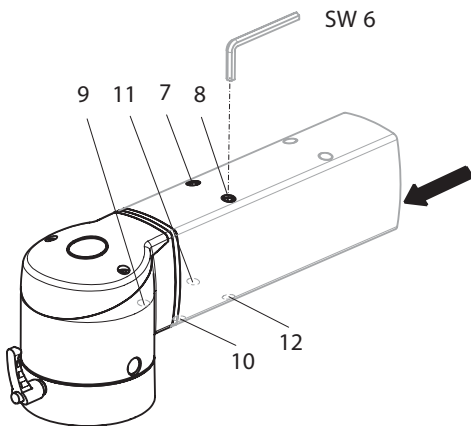

3.3.3 - Press gasket with tube in axial direction while tightening screw 11 and 12 until there is no play
- Maintain pressure while tightening screws 9 and 10 to 20 Nm
- Align tube (see Tube Alignment)

3.3.4

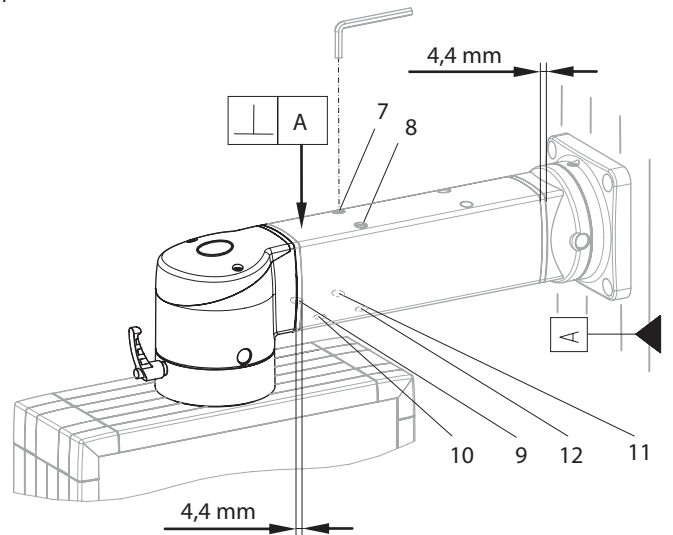

3.3.4 - Secure enclosure to tube
- Align tube (see Tube Alignment)
- Firmly tighten screws in stages
- Check that gap is max. 4.4. mm

4 Tube alignment

4.1 Vertical

4.1.1

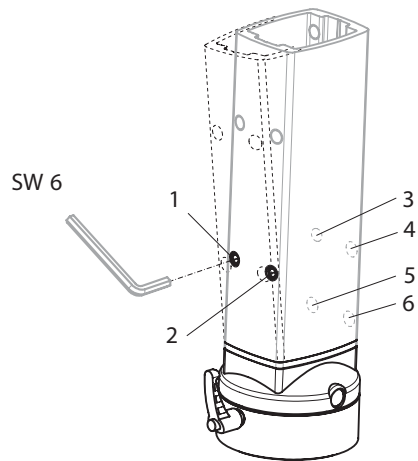
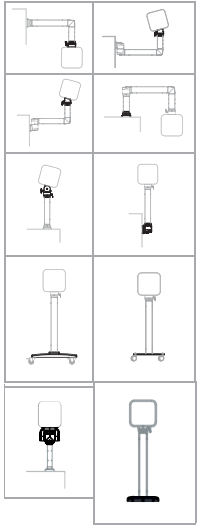

4.1.2

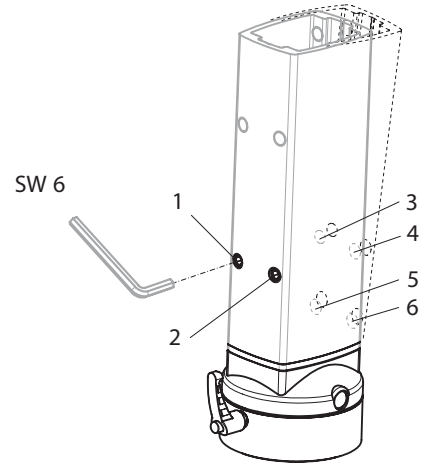

- 4.1.1 - Slacken off screws 3, 4
 - Tighten screws 1, 2
 4.1.2 - Tighten screws 3, 4
 - Slacken off screws 1, 2

4.2 Horizontal Option 1

4.2.1

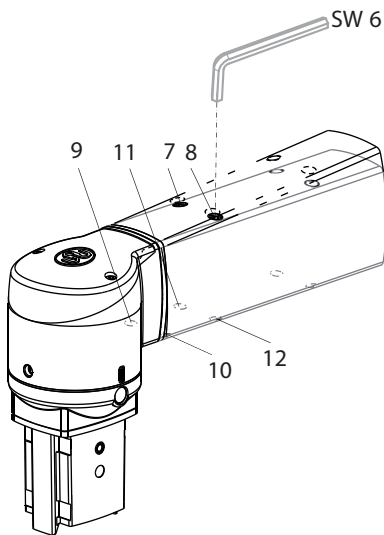
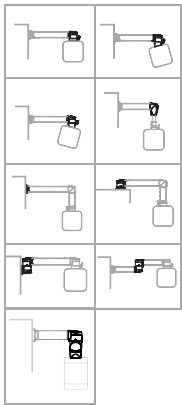

4.2.2

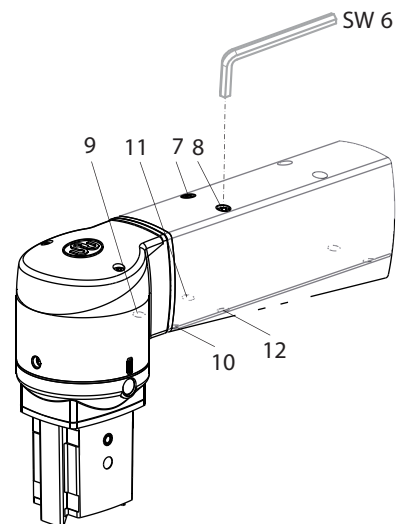

- 4.2.1 - Slacken off screws 11, 12
 - Tighten screws 7, 8
 4.2.2 - Tighten screws 11, 12
 - Slacken off screws 7, 8

4.3 Horizontal

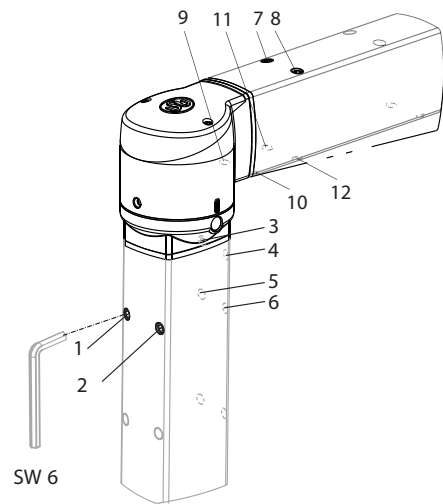
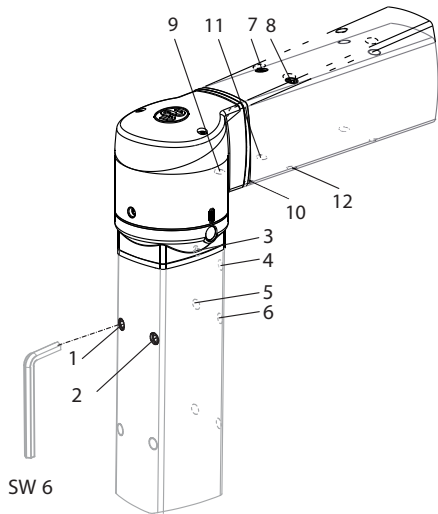
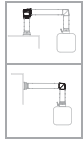

- 4.3.1 - Slacken off screws 5, 6 and tighten screws 1, 2
and/or
- Slacken off screws 11, 12 and tighten screws 7, 8
- 4.3.2 - Tighten screws 5, 6 and slacken off screws 1, 2
and/or
- Tighten screws 11, 12 and slacken off screws 7, 8

5 To ascertain the lever screw in

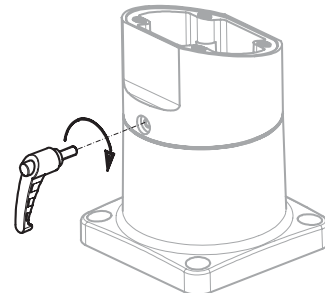
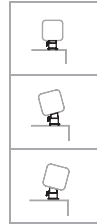
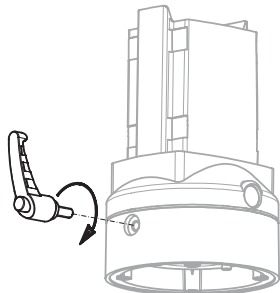
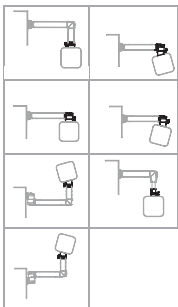

6 Fine adjustment of the tightness

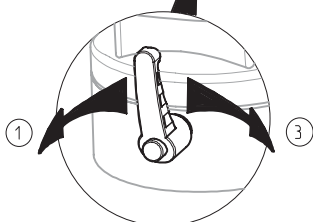
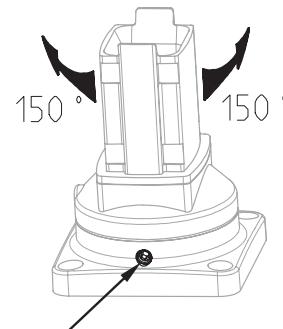
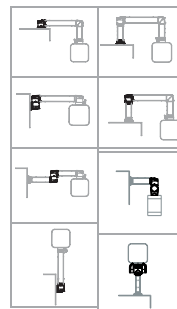
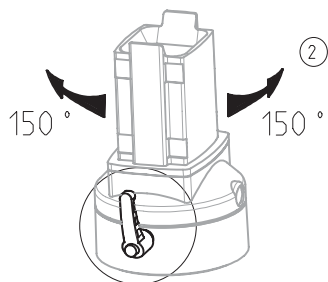
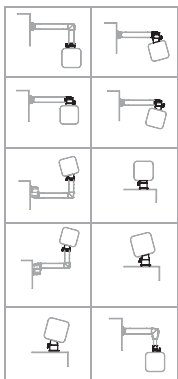

7 Attitude of the tightness of torque (M)



Attention!

The adjustment must be carried out in the not installed condition of the components. It is important to ensure that the component may have no bearing clearance and the plain bearings rest plan after fixing the threaded sleeve.

If the resistance is accomplished in completely installed condition, accepts BERNSTEIN AG no liability for breakage, personal injury or fall of the system.

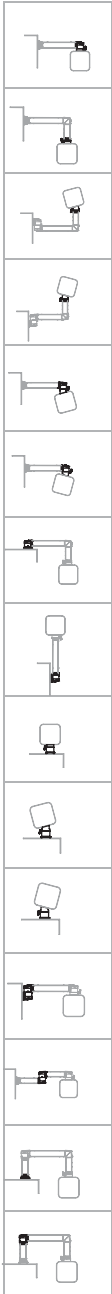

1. Unscrew the cover, if necessary.
2. Loosen cylinder screws M3, so that the screw head lifts 2-3 mm (Abb. 1) (Attention: Do not unscrew completely).
3. Loosen the threaded sleeve anticlockwise with tool item no. 9805421000. (Abb. 5) max. 1 revolution.
4. Set the desired swing torque by tightening the threaded sleeve (Abb. 5).
5. Correct the position of the through holes (as Abb. 2 shows) by tightening clockwise. Attention: Not as shown in Abb. 3!
6. Screw the M3 screws as far as the stop and tighten at 1,5 Nm (Abb.4).
7. Mount the cover, if necessary.



Abb.5

7.1 Attitude of the tightness of torque (M) Turn/ tilt coupling



Unscrew the cover Pos.1
Mount the cover Pos. 5

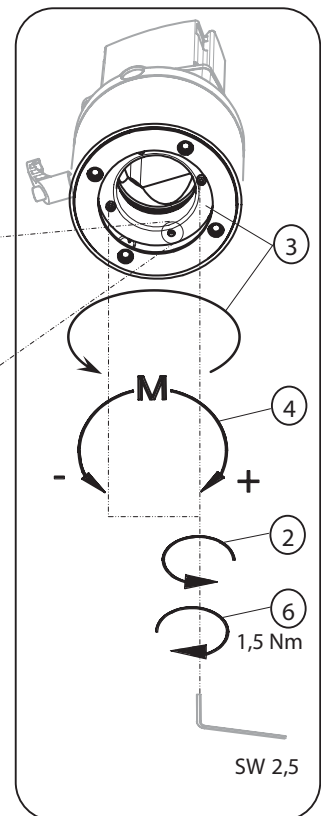
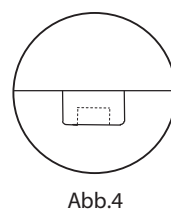
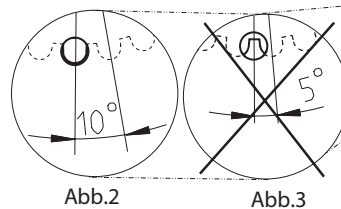
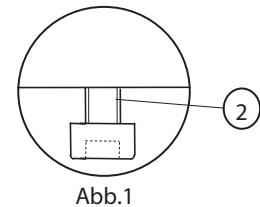
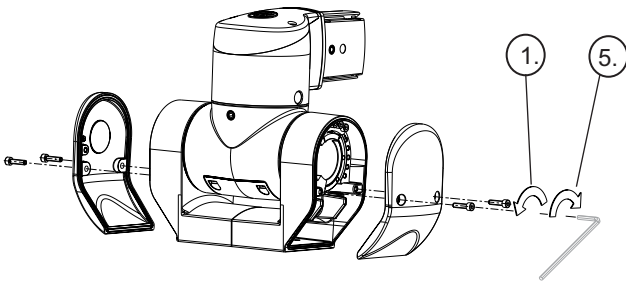
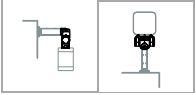
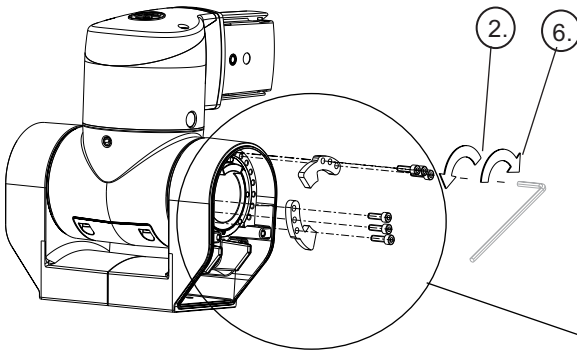

Unscrew the tilt angle limiter Pos.2
Mount the tilt angle limiter Pos. 11

Application examples for tilt angle limiter

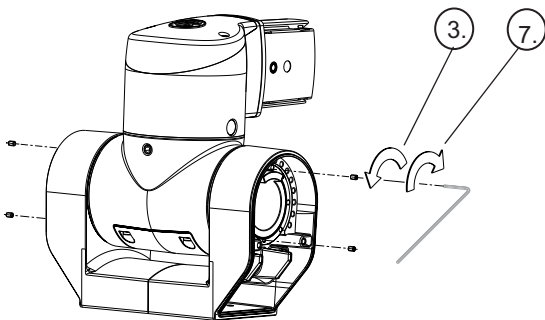
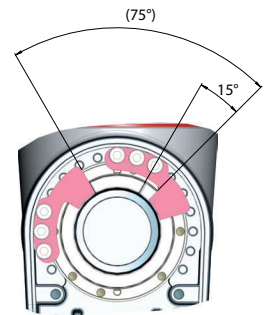
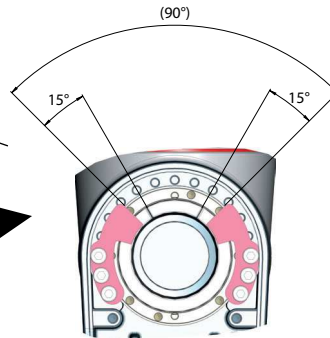

Unscrew the threaded pin M4 Pos. 3 /
Screw the threaded pin M4 Pos. 7

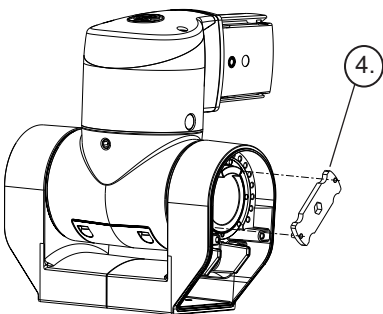

Loosen threaded nut with tool item
no. 980 5422 000. Pos. 4 max. 1
revolution anticlockwise. Set the desired
inclination moment by tightening the
threaded sleeve

Unscrew the cover Pos. 1
Mount the cover Pos. 4

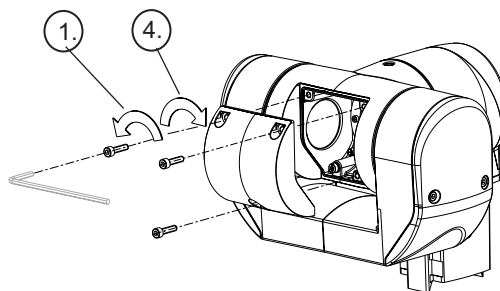

Loosen cylinder screws M3, so that the screw head lifts 2-3 mm. Pos. 2
(Attention: Do not unscrew completely).

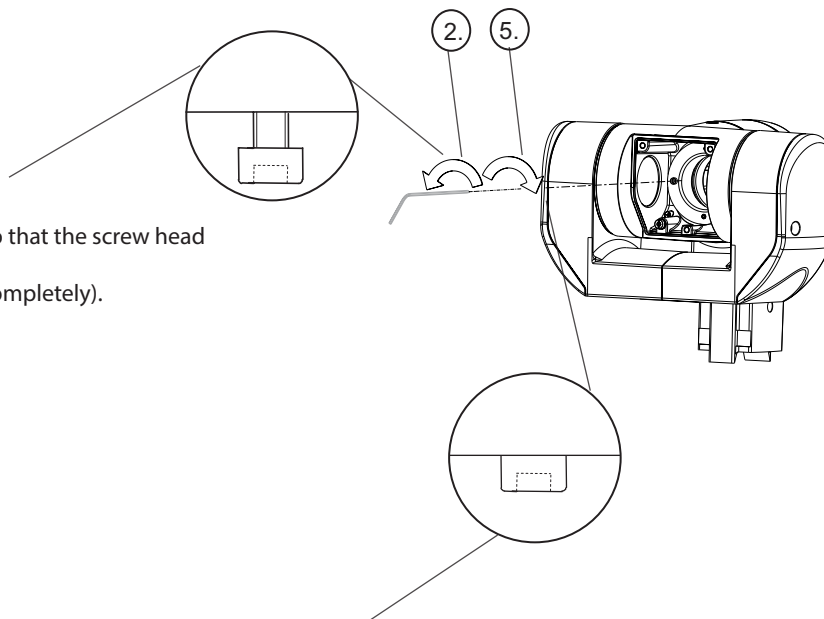

Screw the M3 screws as far as the stop and tighten at 1,5 Nm Pos. 5

Loosen the threaded sleeve anticlockwise with tool item no. 9805421000.
Pos. 3 max. 1 revolution. Set the desired swing torque by tightening the threaded sleeve

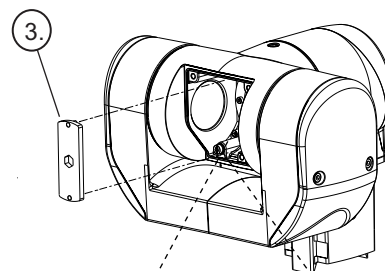

Correct the position of the through holes (as Abb. 2 shows) by tightening clockwise. Attention: Not as shown in Abb. 3!



Abb.2

Abb.3

8 Fixing at enclosure

8.1 Standard

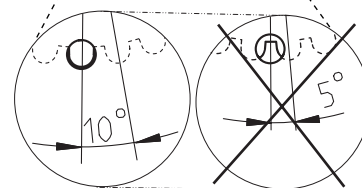
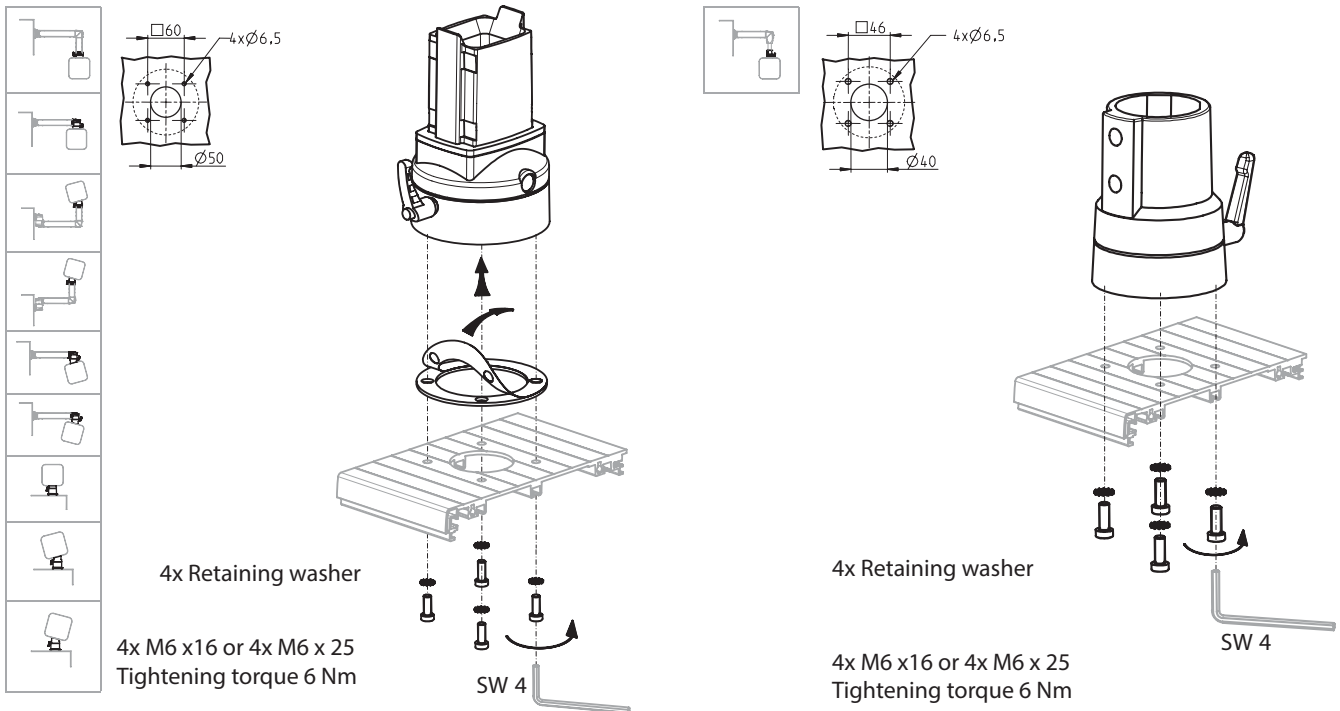

8.2 Turn/tilt coupling W

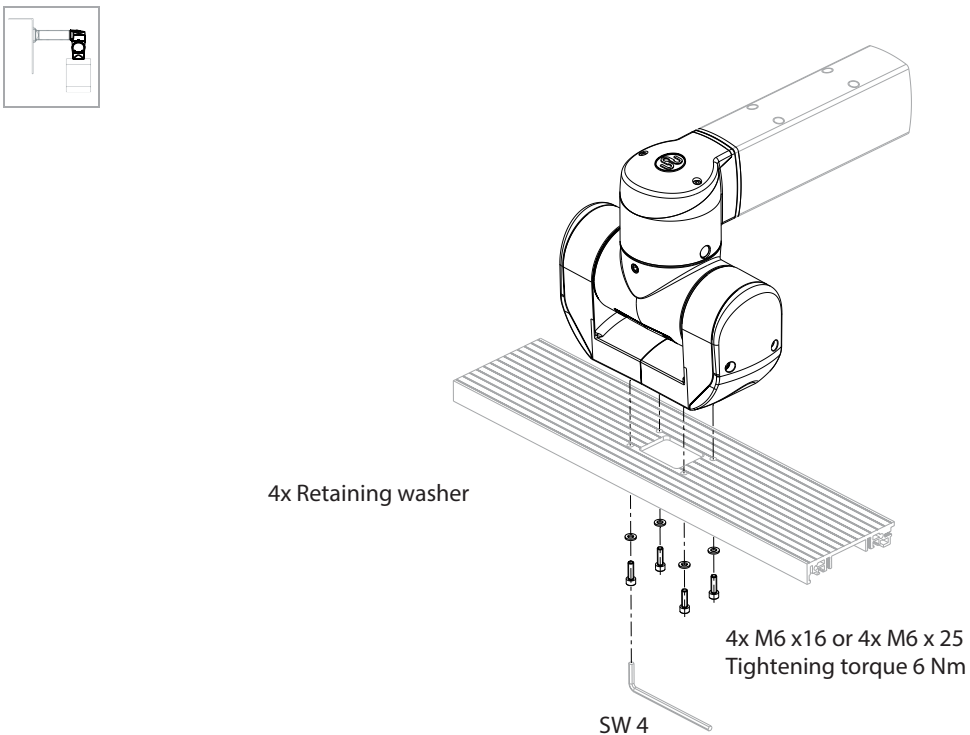

8.3 Turn/tilt coupling S

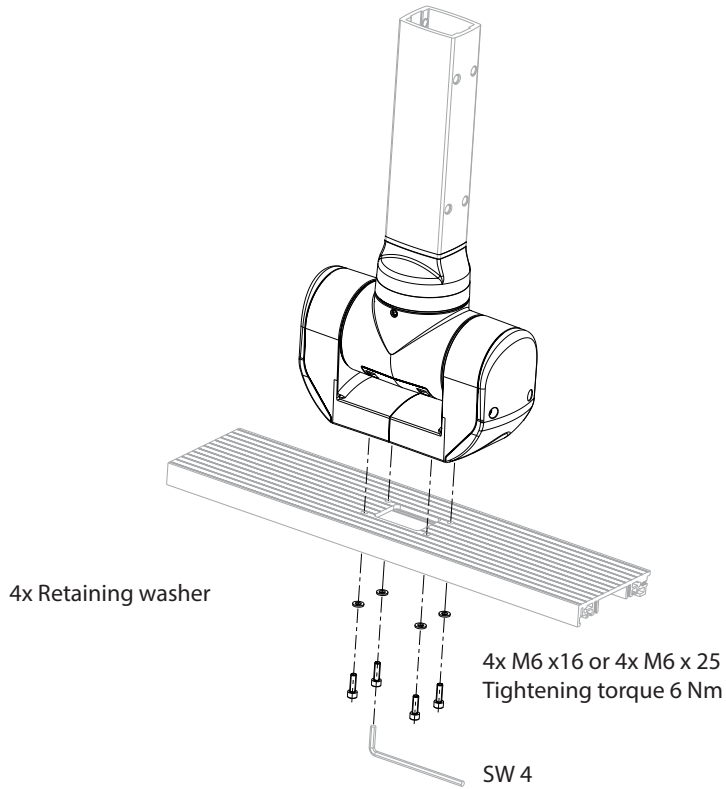
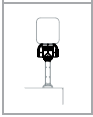

8.4 with adapter plate VESA 75/100

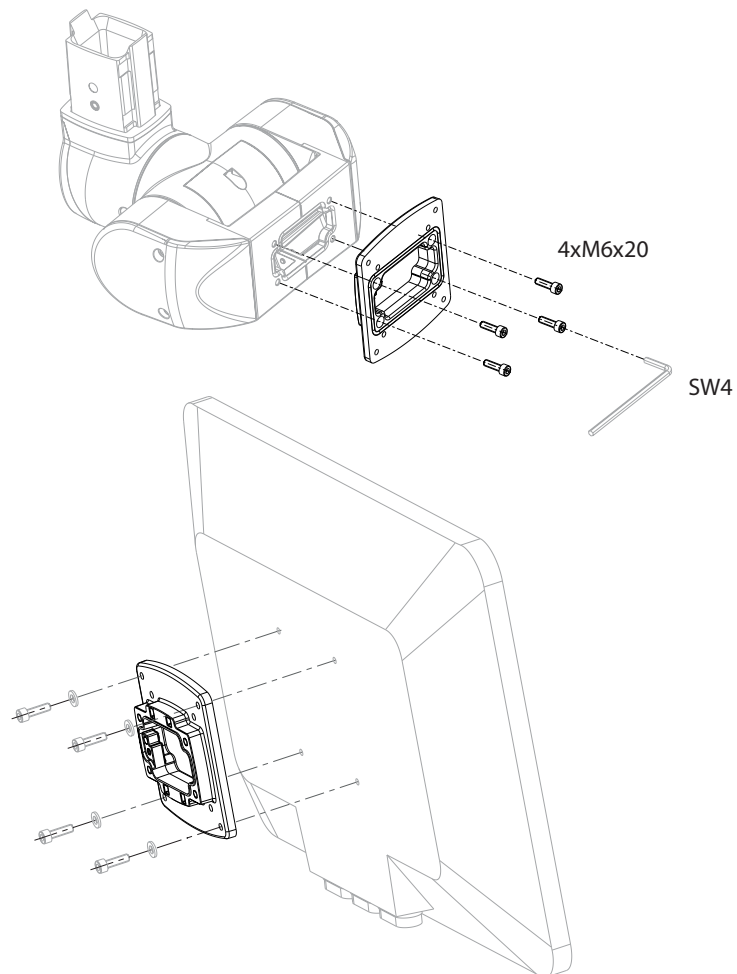
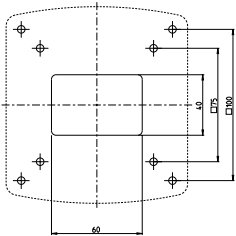

9 Mounting on building or machine

9.1 Standard

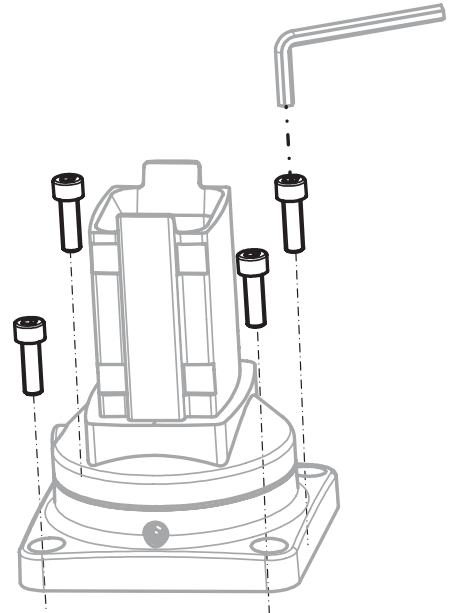
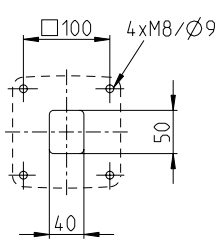
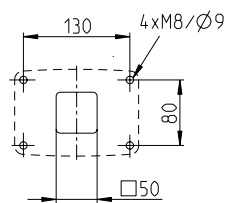
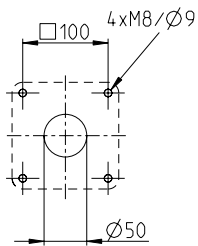
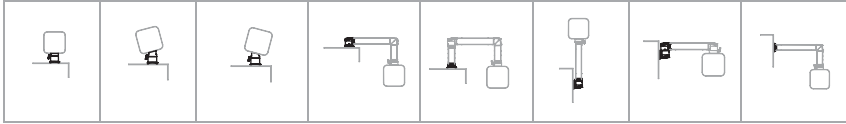

9.2 with small base

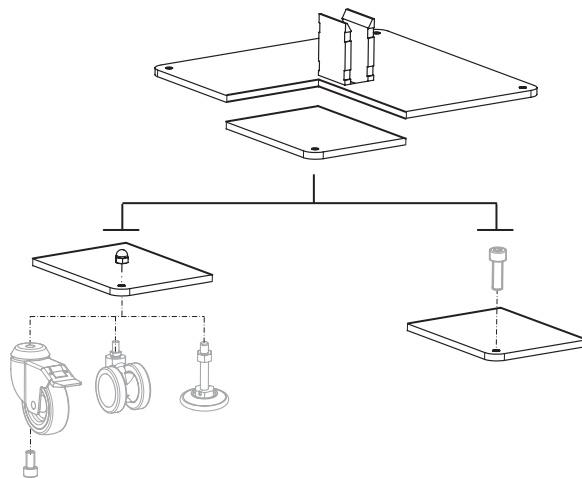
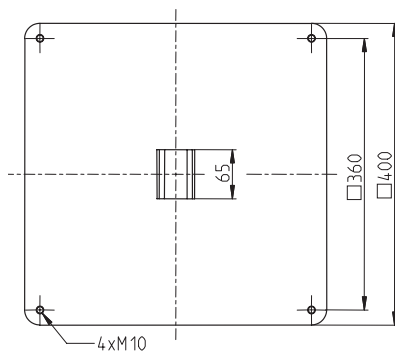

See "Accessories for Bases" Page 16

9.3 with FLEX.base

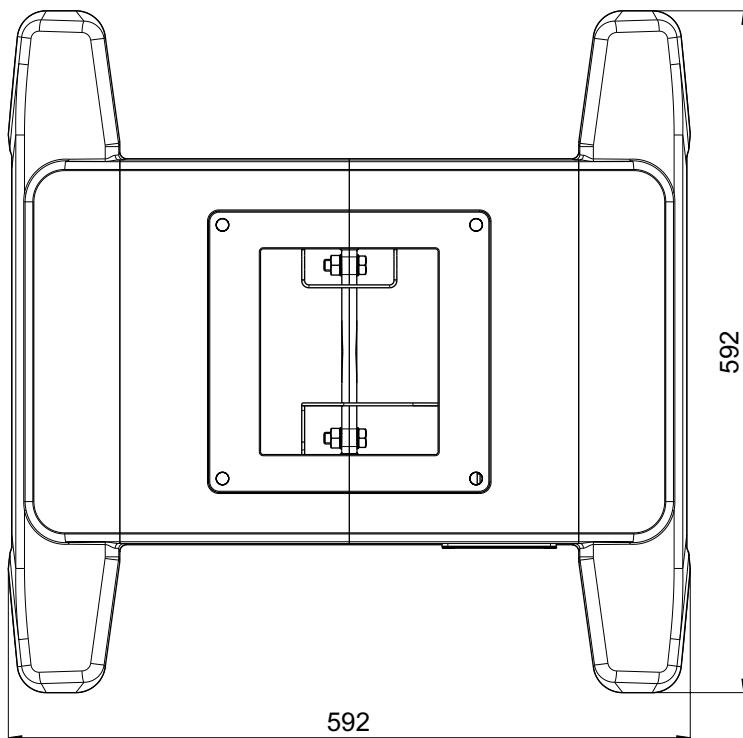
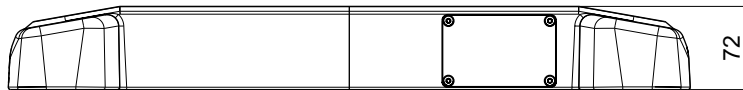
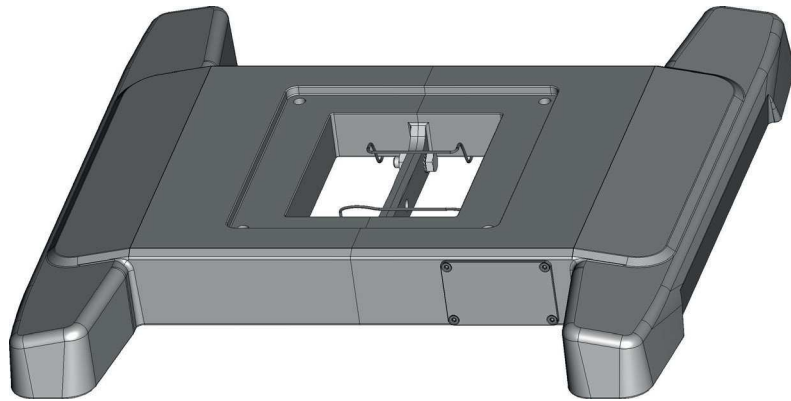

Installation for Large Base see separate installation instruction

See "Accessories for Bases" Page 16

10 To crew link cap

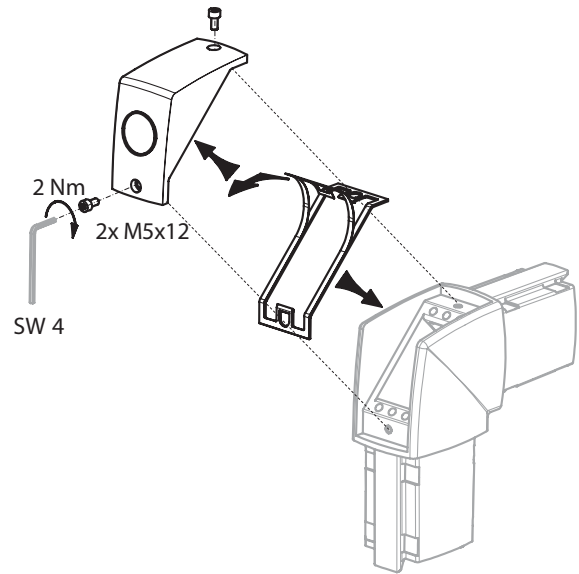
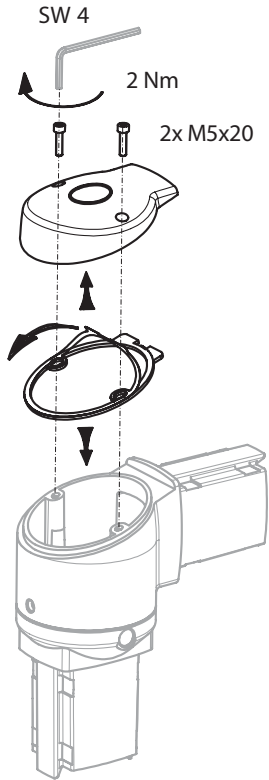
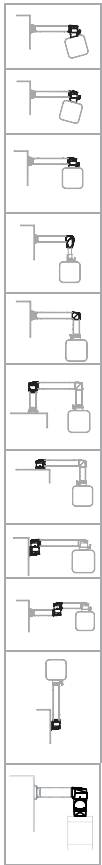

11 Accessories

Art No.

S2MRL

Type

Rotation limiters

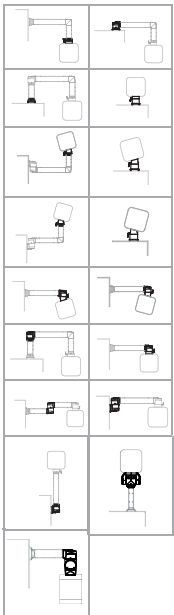

Scope of supply
1x Cap
10x Bills

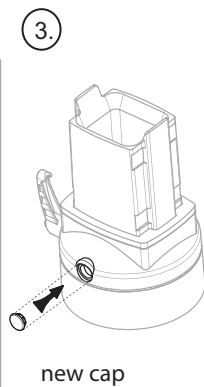
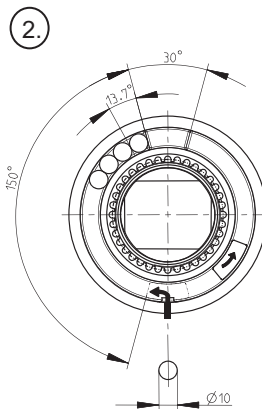
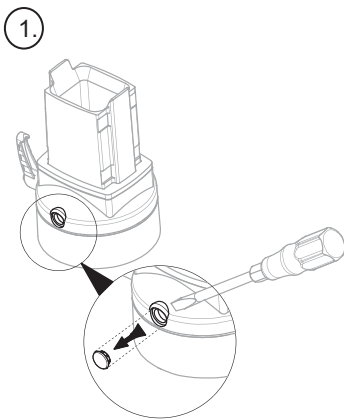

$x^\circ = \text{Rotation}$
 $n = \text{Number of bills per side}$
 $x^\circ = 150^\circ - (n \times 13,7^\circ)$

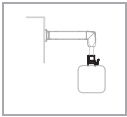

1.

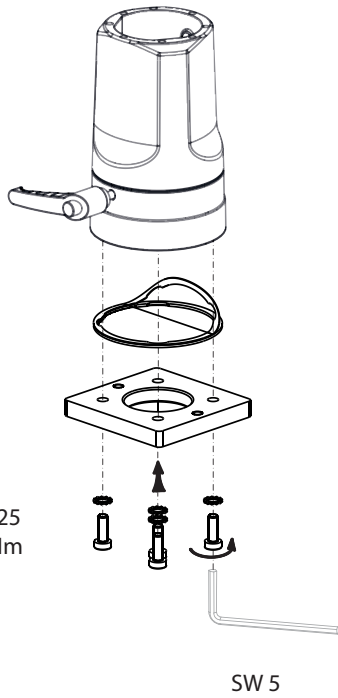

4x Retaining washer

4x M6 x16 or 4x M6 x 25
Tightening torque 6 Nm

SW 5

2.

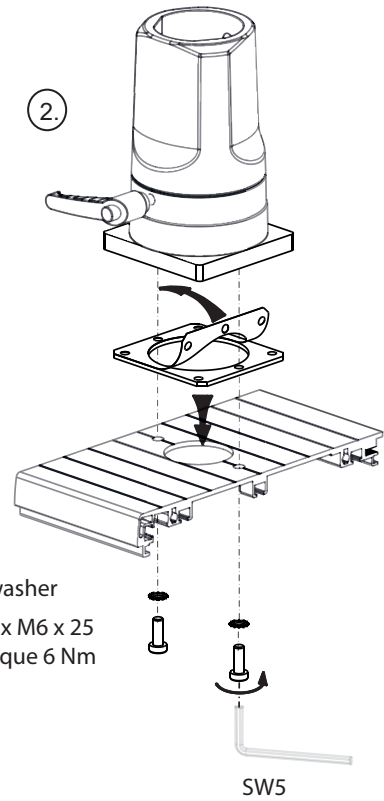

2x Retaining washer
2x M6 x16 or 2x M6 x 25
Tightening torque 6 Nm

SW5

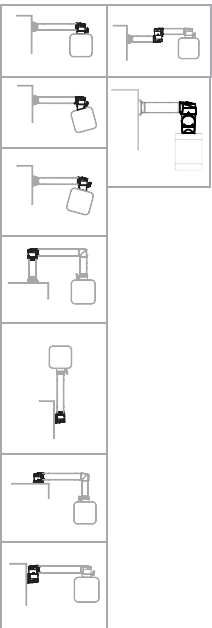

1.

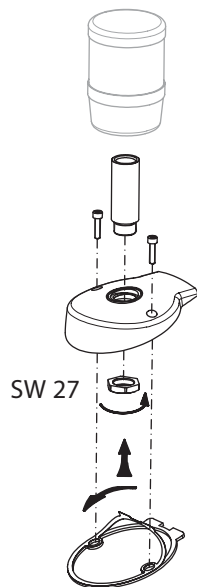

SW 27

2.

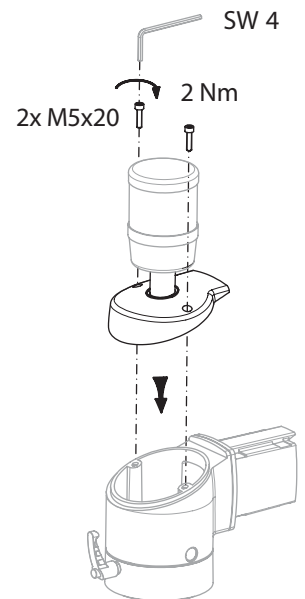

2x M5x20
2 Nm

SW 4

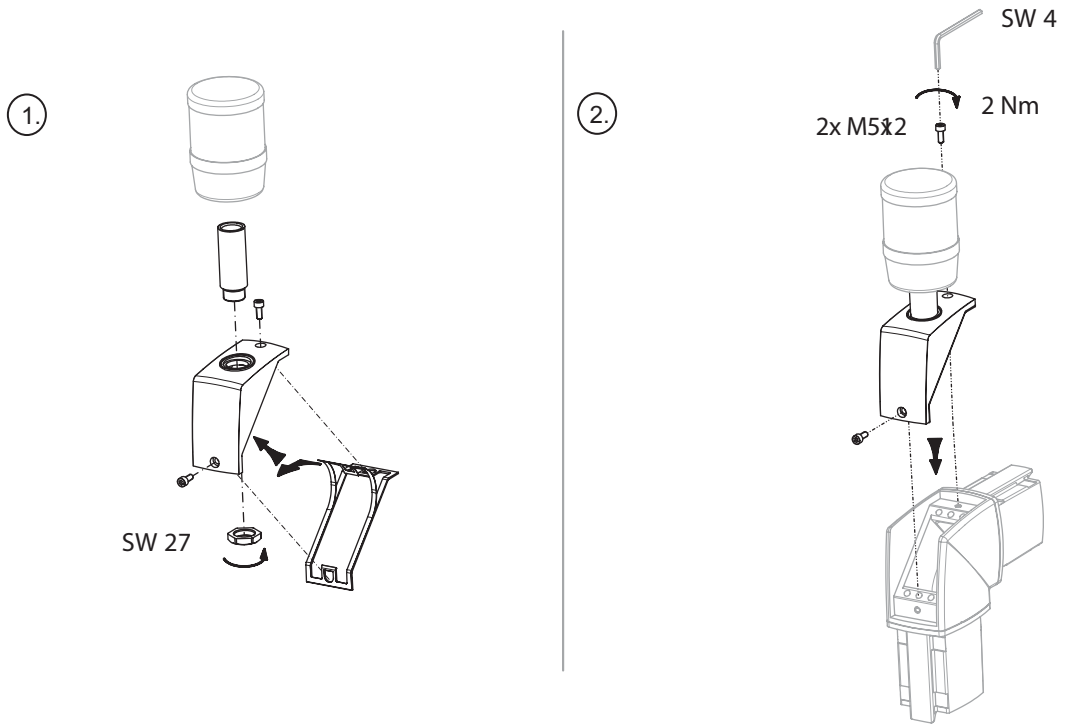
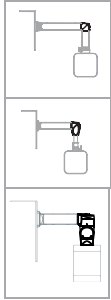

12 Accessories for bases

available separately

separate installation instructions

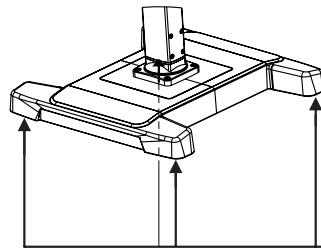

Industrial castors



4x

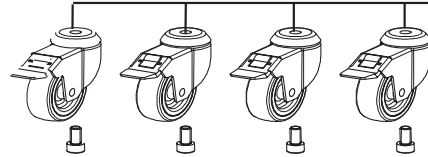

Apparatus castors

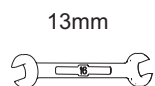

2x

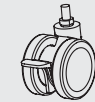

2x

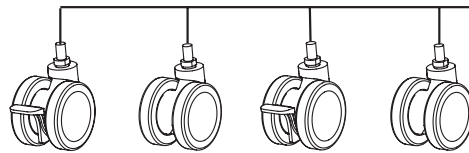
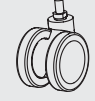

Support feet

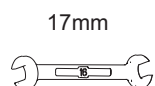

4x

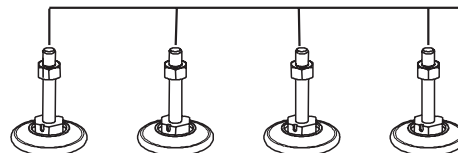
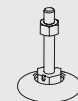

13 Mechanical Data

Material

Komponenten	GD-AI
Large base	GD-AI
Small base	Steel
Gasket	Neoprene
Plastics	PA / POM
Protection class	IP65 (except bases)

14 Load diagram SYSPEND 281-MAX

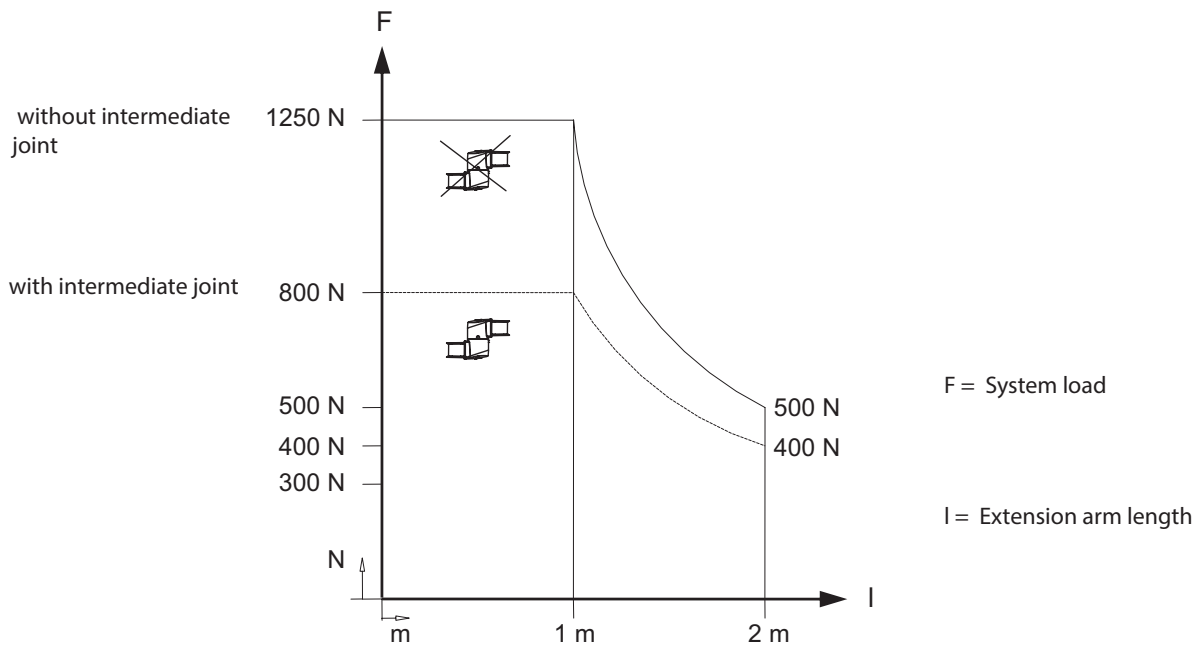

15 Tube Cutoff

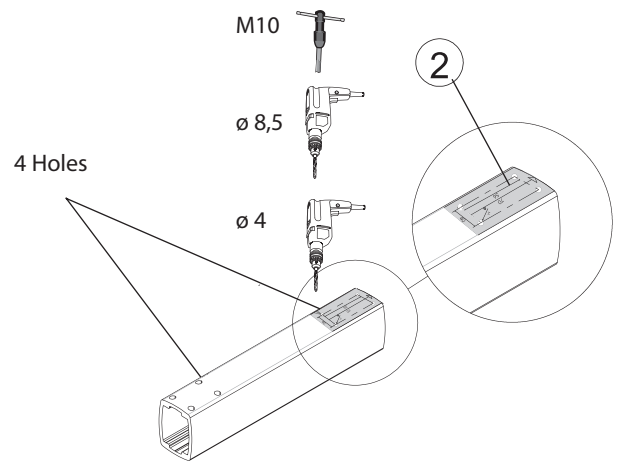
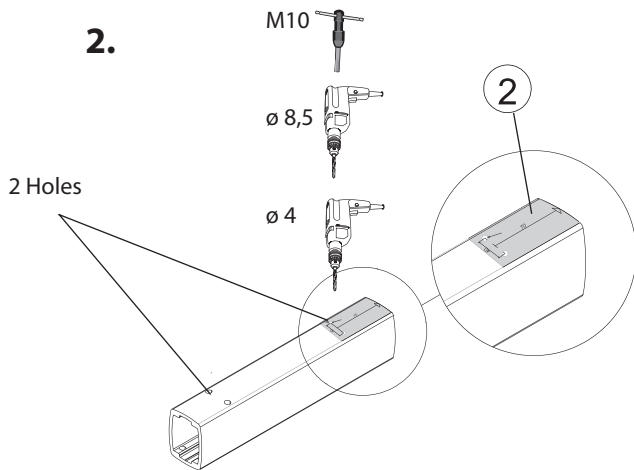
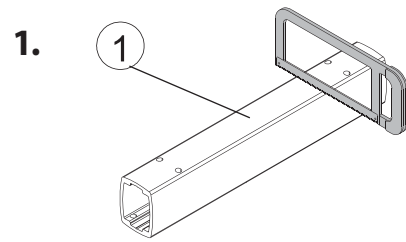
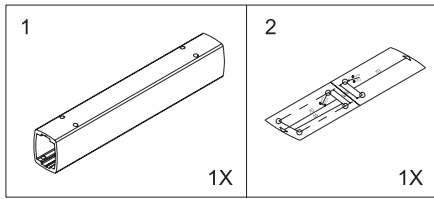

The original operating and installation instructions are the German language version.
Other languages are a translation of the original operating and installation instructions.