

## Installation and Operating Instructions: 168FLR or 274FLR Loadbreak Fused Elbow Connector

**CONTENTS:** Cable Half Housing, Elbow Half Housing, Fuse, Compression Lug, Probe, Probe Connector, Hose Clamp, Probe Wrench, Allen Wrench, Lubricant, Installation/Operating Instructions.

The 168FLR and 274FLR are designed to provide an in line full range current limiting fuse while terminating UD cable having concentric neutral and extruded insulation shielding. When other types of UD cable are to be terminated, an appropriate Elastimold cable shield or grounding device must be used.

The 168FLR elbow provides an operating interface for connecting to an Elastimold 15kV class (8.3kV phase-to-ground and 14.4kV phase-to-phase) 200 ampere loadbreak bushing or accessory device with fault close rating of 10,000 amperes RMS symmetrical.

The 274FLR elbow provides an operating interface for connecting to an Elastimold 25kV class (15.2kV phase-to-ground and 26.3kV phase-to-phase) 200 ampere loadbreak bushing or accessory device with fault close rating of 10,000 amperes RMS symmetrical. The 274FLR elbow provides an operating interface for connecting to an Elastimold 25kV class (15.2kV phase-to-ground and 26.3kV phase-to-phase) 200 ampere loadbreak bushing or accessory device with fault close rating of 10,000 amperes RMS symmetrical.

### DANGER

**All apparatus must be de-energized during installation or removal of part(s) except for test point caps and indicators that can be installed and operated energized.**

**Do not touch or move energized products in the work area.**

**These instructions do not attempt to provide for every possible contingency.**

**Failure to follow these instructions will result in damage to the product and serious or fatal injury.**

**This product should be installed only by competent personnel trained in good safety practices involving high voltage electrical equipment. These instructions are not intended as a substitute for adequate training or experience in such safety practices.**

**All apparatus must be installed and operated in accordance with individual user, local and national work rules and electrical standards.**

**FOR MORE INFORMATION ON PARTS, INSTALLATION RATINGS AND COMPATIBILITY, CALL THE NEAREST ABB OFFICE.**

**If this product is supplied with a protective shipping cover(s), remove this shipping cover(s) and replace with the appropriate HV insulated cap(s) or connector(s) before submerging or energizing the circuit.**

**Inspect parts for damage, rating and compatibility with mating parts.**

**Excess distortion of the assembled product may result in its failure.**

**After installation loadbreak products can be operated energized per operating instructions. All deadbreak connectors must be de-energized before operating.**

**Connectors must be operated with a full insulated "hotstick" type tool. Consult the company's safe work practices for the required tool length.**

### Limited Warranty:

1. ABB Installation Products Inc. warrants that its products will be free from defects in materials or workmanship for a period of two (2) years, except for tools which are warranted separately (see warranty accompanying those products). Fisher Pierce<sup>®</sup> products and Elastimold<sup>®</sup> Reclosers are warranted for three years; and Joslyn<sup>®</sup> VBT and VBU capacitor switches are warranted for four years or 40,000 operations whichever occurs first. Upon prompt notification of a warranted defect, ABB Installation Products Inc. will, at its option, repair or replace the defective product.
2. In no event shall ABB Installation Products Inc. be liable for any consequential, indirect or special damages, nor will ABB Installation Products Inc. be liable for transportation, labor, or other charges arising out of the removal or reinstallation of its products. Liability for breach of warranty is limited to the cost of repair or replacement of the warranted product only.
3. Misuse, misapplication or modification of ABB Installation Products Inc. products immediately voids all warranties.

**THE WARRANTIES AND REMEDIES CONTAINED HEREIN ARE EXCLUSIVE AND ARE IN LIEU OF ALL OTHER WARRANTIES AND REMEDIES, INCLUDING BUT NOT LIMITED TO ANY IMPLIED WARRANTIES OF MERCHANTABILITY AND FITNESS FOR A PARTICULAR PURPOSE, WHICH ARE SPECIFICALLY DISCLAIMED.**

### IMPORTANT

1. Check contents of package to ensure they are complete and undamaged.
2. Check all components to ensure proper fit with cable and/or mating products.
3. Check threads by threading probe into compression lug. If resistance is encountered prior to full assembly, check for damage and replace damaged component.
4. Read entire installation instructions before starting.
5. Have all required tools at hand and maintain cleanliness throughout the procedure.

**CAUTION: Lubricate test point cap, V2 voltage detector or test point fault indicator and assemble tightly.**

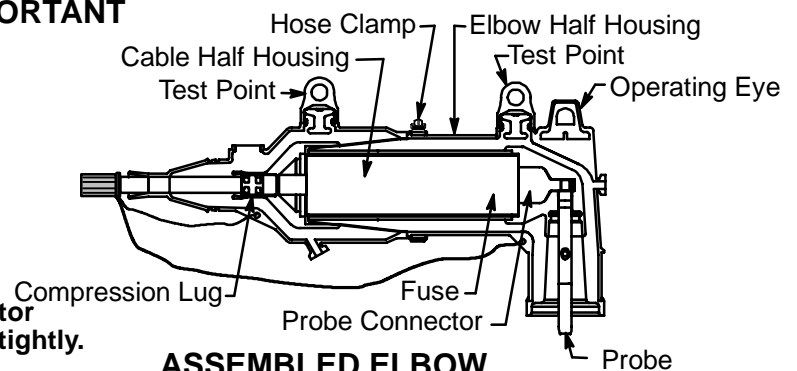

**ASSEMBLED ELBOW**

## STEP 1 Cable Training

1. Using the bushing centerline as reference, cut excess cable off 20" minimum beyond bushing.
2. Slide optional 200ECS Cold Shrink Cable Seal onto cable.
3. Remove the jacket from the excess cable length remaining AND the distance of "A" (as defined) + 7-3/8" from the bushing centerline.
4. If a Cable Seal kit is used, follow the instructions provided. Otherwise, unwrap and fold the Concentric Neutral wires back over the jacket, and bind.
5. Using the bushing centerline as reference, squarely cut off the cable a distance of "A", leaving 7-3/8" minimum of cable to terminate. **Distance "A"** represents the length of the fuse body.

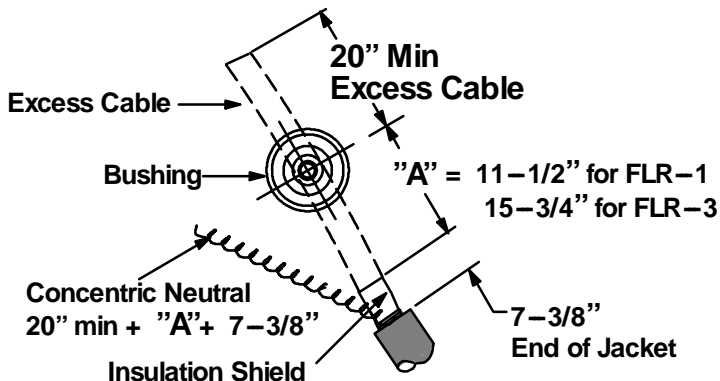

## STEP 2 Cable Preparation

(Cable Cut Back Diagram located in the left margin is NOT to scale and is provided for reference only.)

1. Cut 1-1/8" from the cable end. Cut squarely taking care not to nick conductor.
2. Wire brush bare aluminum conductors and immediately install compression lug. Rotate to spread inhibitor. Crimp the unthreaded end of the compression lug to the conductor (refer to crimp chart packaged with the compression lug for recommended crimp tool information.) Start crimp at the crimp line mark. Rotate 180\_ each successive crimp. Carefully wipe excess inhibitor from the outside of the lug and cable.
3. Remove insulation shield 5-1/2" from end of lug. Bevel insulation end 1/8" max.
4. Thoroughly clean insulation to remove all traces of conductive residue.

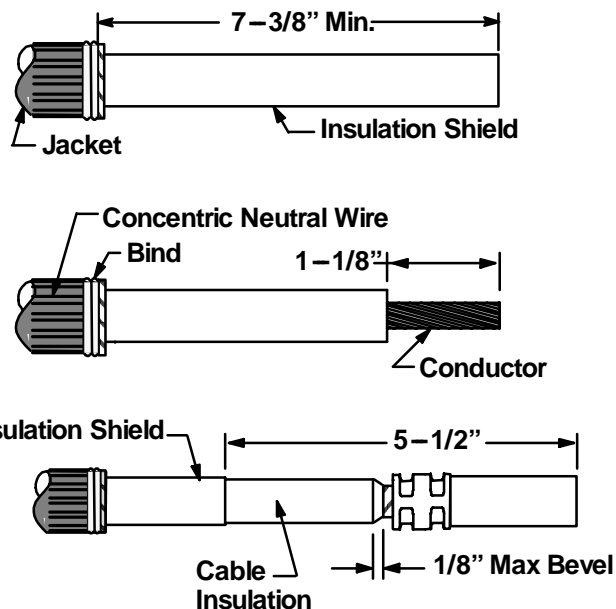

## STEP 3

Apply lubricant to the outside of the connector, cable insulation and conductive shield, and the cable half of the Fused Elbow cable entrance end. (Use lubricant supplied. DO NOT SUBSTITUTE). Insert connector and cable into the cable half of the Fused Elbow until the top end of the connector protrudes beyond surface "A". The purpose of this is to allow the fuse to be tightened before bottoming on the rubber.

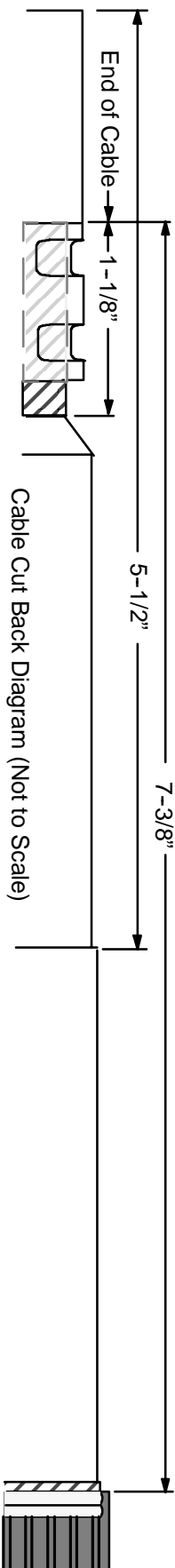
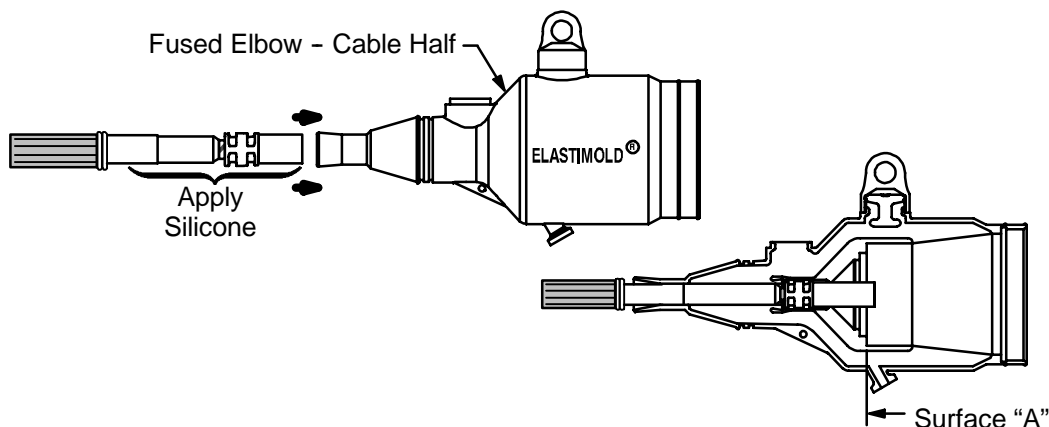

Cable Cut Back Diagram (Not to Scale)

### STEP 4

Insert the threaded terminal end of the fuse into the cable half of the Fused Elbow and thread it into the cable connector. **HAND TIGHTEN. CAUTION: Fuse stud will fracture if over torqued.** Pull the housing up against the bottom of the tightened fuse.

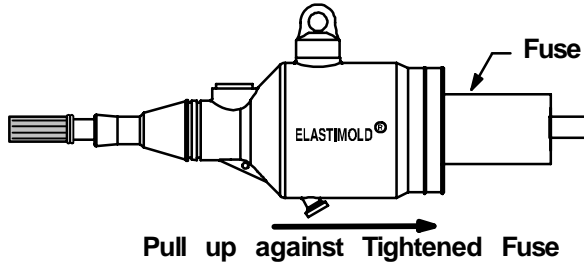

### STEP 5

Assemble the probe connector to the fuse terminal. Rotate the probe connector so that the flats are perpendicular to the bushing with which it will mate. Lock the probe connector in position. Tighten the setscrews using the special torque limiting allen wrench supplied in the fuse kit. Rotate the cable half of the Fused Elbow so that the test point is perpendicular to the flats on the probe connector.

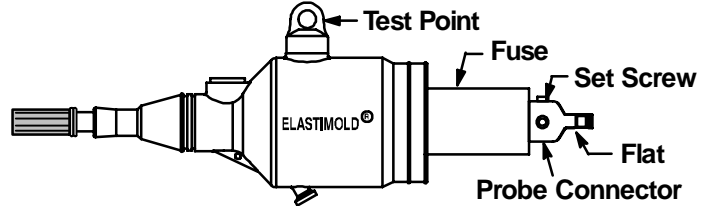

### STEP 6

1. Apply lubricant to the elbow half of the fused elbow and assemble it to the cable half of the fused elbow. The cuff of the cable half will overlap the elbow half by 3/4". Make sure that the probe connector faces the opening of the fused elbow half. The two test points should be in line with each other.
2. Insert the probe into the probe connector. It may be necessary to push on the cable to get the probe to line up with the fuse. Start the threads by hand, taking care, not to cross thread the probe. To tighten use the special torque limiting allen wrench supplied. Insert the short end of the wrench into the hole in the probe; tighten until the wrench bends and remains bent.
3. Position hose clamp as shown and tighten. **DO NOT OVERTIGHTEN.**

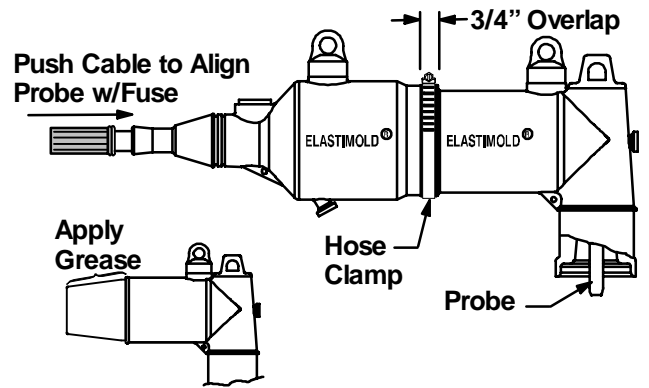

### STEP 7 Concentric Neutral Connection

1. Using a separate copper wire (No. 14 AWG / 2.5mm) or equivalent, insert one end through each grounding eye on the elbow housing and cable housings. Twist tightly taking care not to damage eye.
2. Finish installing 200ECS jacket seal if used.
3. Twist all neutral wires, exercise care to not damage grounding eyes and connect to ground using appropriate connector. Provide adequate slack in wires for elbow operation.

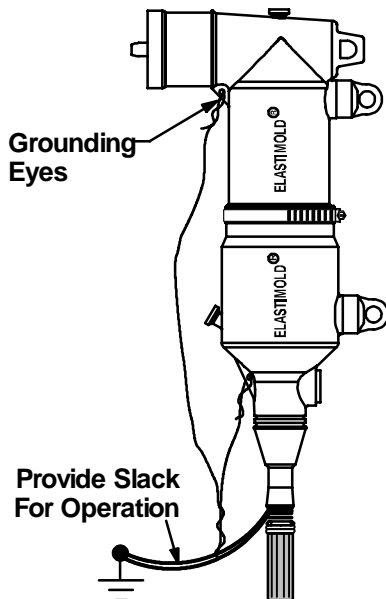

### STEP 8 Connect Elbow and Bushing Plug

1. Lubricate the receptacle portion of the elbow connector and the mating bushing with the lubricant supplied. **LUBRICATE ONLY IF THE TRANSFORMER AND ELBOW ARE KNOWN TO BE DE-ENERGIZED.**
2. Operate per following instructions. **DO NOT OPERATE BY HAND.**

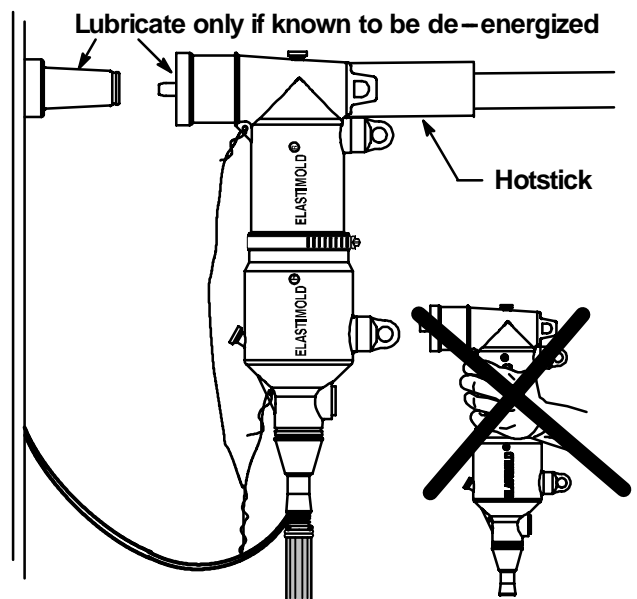

# OPERATING INSTRUCTIONS

## Before Loadmake or Loadbreak Operation:

Loadbreak connectors must be operated with a full insulated "hotstick" type live-line tool. Consult the company's safe work practices for the required live-line tool length.

Area must be clear of obstructions or contaminants that would interfere with the operation of the connector. This area should allow you to establish firm footing and enable you to grasp the hotstick tool securely, maintaining positive control over the movement of the loadbreak connector before, during and directly after the operating sequence. Because of the control, speed and force required to engage or disengage the elbow, certain operating positions are more advantageous than others. If there is some question as to proper operating position, it is recommended that the connectors be operated de-energized. Do not connect two different phases of a multiple-phase system. Before closing a single-phase loop, make certain both ends of the loop are the same phase.

## LOADMAKE OPERATION

1. Area must be clear of obstructions or contaminants that would interfere with the operation of the connector.
2. In preparing bushing for elbow connector, remove insulated cap by attaching hotstick tool to the insulated cap pulling eye, and following the instructions for this accessory, remove from bushing.
3. Securely fasten a hotstick to the loadbreak connector pulling eye.
4. After establishing firm footing and positive control of the elbow connector, withdraw the elbow from the accessory device on the apparatus parking stand with a fast, straight, firm motion being careful not to place the elbow connector near a ground plane.

Check appropriate accessory device operating instructions to be sure that the device is rated for energized operation.

5. Place the elbow connector receptacle area over the bushing plug, inserting the elbow male contact (arc follower portion) into the bushing until the first slight resistance is felt. Resistance is felt when the arc follower portion of the male contact first meets the female contact of the bushing (at this point the contacts are approximately 2" apart).

**DO NOT HOLD IN THIS POSITION BUT IMMEDIATELY PUSH THE ELBOW HOME WITH A FAST, FIRM, STRAIGHT MOTION.** Apply sufficient force to engage the internal lock on the elbow connector and bushing interface.

## Fault Close

1. **It is not recommended that operations be made on known faults.**
2. If a fault closure is experienced, the elbow housing, the probe and the bushing insert must be replaced.

## LOADBREAK OPERATION

1. Place desired accessory device on apparatus parking stand.  
Refer to appropriate operating instructions for accessory device to be used. Be certain it is rated for energized operation.
2. Firmly tighten a hotstick to the loadbreak connector pulling eye.
3. Without exerting any pulling force, slightly rotate the connector clockwise in order to break surface friction prior to disconnection.
4. Withdraw the connector from the bushing with a fast, firm, straight motion, being careful not to place the connector near a ground plane.
5. Place connector on appropriate accessory device, following the operating instructions for that accessory.

## VOLTAGE TEST ON 168/274FLR

The ELASTIMOLD loadbreak fused elbow connector is equipped with two integral capacitance test points that can be used to establish whether or not the fuse has interrupted the circuit. For an open fuse, the test point on the feed side will indicate a voltage and the test point on the load side will indicate no voltage. If the fuse has not opened both test points will indicate a voltage. When using the test point, complete the following steps:

1. Remove test point cap with a hotstick. When removing cap, PEEL OFF AT AN ANGLE rather than pulling directly in line with the test point assembly.
2. **WARNING: THE VOLTAGE TEST POINT IS A CAPACITANCE DEVICE, IT IS NOT DIRECTLY CONNECTED TO THE CONDUCTOR.** Do not use conventional voltage measuring equipment. Follow the manufacturer's directions for the meter that is used. Test with a suitable sensing device, made for use with separable connectors manufactured with capacitive test points, to determine if cable is energized. Contamination, moisture, dirt, etc. around the test point or use of the wrong measuring equipment can provide a false "no voltage" indication on an energized elbow. To prevent serious or fatal injury treat the elbow as energized until the "no voltage" test point indication is confirmed by other means.
3. After voltage detection has been made, clean and lubricate the inside surface of the cap with lubricant supplied and replace it on the test point.

## REPLACING CLEARED FUSE

**DANGER: DO NOT ATTEMPT TO REPLACE THE FUSE IF THE FUSED ELBOW IS ENERGIZED, THIS WILL RESULT IN SERIOUS OR FATAL INJURY.**

1. With the de-energized elbow removed from the bushing use the torque limiting wrench to remove the probe.
2. Loosen the hose clamp on the body of the elbow.
3. Insert a vent stick between the Fused Elbow cable half and probe half to aid separation of the halves.
4. Remove the probe connector from the fuse by loosening the allen setscrew.
5. Unscrew by hand the cleared fuse from the cable half.
6. Install new fuse as shown in STEPS 4-6 of this instruction sheet.