



### Short-Circuit Current Ratings (SCCR) and Branch Circuit Protection



The Short-Circuit Current Ratings (SCCR) and Branch Circuit Protection combinations have been tested per IEC61800-5-1 and are in the ATV12 User manual. For more information refer to the ATV12 User manual (<https://www.se.com/ww/en/download/document/BBV28581/>).

The combinations in the table below have been tested per UL61800-5-1 (Reference UL file E116875). These ratings allow proper coordination of short circuit protection.

ATV12 drives are provided with integral overload and over-speed monitoring after activation of the function [Motor thermal state memo] 9 N 9 . and can provide motor overload protection at 100% of the full load motor current. The motor thermal current [Motor Th Current] E N D must be set to the rated current indicated on the motor nameplate. For more information refer to the ATV12 User manual (<https://www.se.com/ww/en/download/document/BBV28581/>).

The opening of the branch circuit protective device may be an indication that a fault current has been interrupted.

#### ⚠️ ⚠️ DANGER

#### HAZARD OF ELECTRIC SHOCK, EXPLOSION, OR ARC FLASH

- Current-carrying parts and other components of the controller should be examined and replaced if damaged.
  - If burnout of the current element of an overload relay occurs, the complete overload relay must be replaced.
- Failure to follow these instructions will result in death or serious injury.**

75°C (167°F) copper conductor with the AWG wire size shown on nameplate for all sizes.

Suitable for use on a circuit capable of delivering not more than  X  rms symmetrical kiloAmperes,  Y  Volts maximum, when protected by  Z1  with a maximum rating of  Z2 .

Altivar 12 Short Circuit Current Ratings <sup>1 2</sup> With Enclosure, Without Line Reactor										With Circuit Breaker		With QO Circuit Breaker			With GV•P			Fuses			Line Reactor Min Value <sup>8</sup>	
Input Voltage 50/60 Hz (Y)	Power Ratings		Catalog Number <sup>7</sup>	Minimum Enclosure Volume		PowerPact <sup>3</sup> Catalog Number (Z1, Z2)	SCCR (X)	QO QOB	QOU	Rating	SCCR (X)	GV•P (Z1, Z2)			SCCR (X)	600 V Class J <sup>5</sup> (Z1, Z2)	SCCR (X)	Line Reactor Min Value <sup>8</sup>				
												Type E <sup>4</sup>	Voltage Rating	Power <sup>6</sup>								
	(kW)	(HP)										(L)	(in3)	(kA)						(A)	(kA)	(V)
120 Vac Single-phase	0.18	1/4	ATV12H018F1	15.7	960	H•L36015	5 <sup>9</sup>	yes	yes	10	5 <sup>1,2</sup>	GV2P10	120	1/4	5 <sup>9</sup>	15	5 <sup>9</sup>	-	-			
	0.37	1/2	ATV12•037F1	15.7	960	H•L36020	5 <sup>9</sup>	yes	yes	20	5 <sup>1,2</sup>	GV2P14	120	1/2	5 <sup>9</sup>	25	5 <sup>9</sup>	-	-			
	0.75	1	ATV12H075F1	15.7	960	H•L36025	5 <sup>10</sup>	yes	yes	25	5 <sup>1,3</sup>	GV2P20	120	1	5 <sup>10</sup>	40	5 <sup>10</sup>	-	-			
240 Vac Single-phase	0.18	1/4	ATV12H018M2	15.7	960	H•L36015	5 <sup>9</sup>	yes	yes	10	5 <sup>1,2</sup>	GV2P08	240	1/3	5 <sup>9</sup>	7	5 <sup>9</sup>	-	-			
	0.37	1/2	ATV12•037M2	15.7	960	H•L36015	5 <sup>9</sup>	yes	yes	10	5 <sup>1,2</sup>	GV2P10	240	1/2	5 <sup>9</sup>	15	5 <sup>9</sup>	-	-			
	0.55	3/4	ATV12•055M2	15.7	960	H•L36015	5 <sup>9</sup>	yes	yes	15	5 <sup>1,2</sup>	GV2P14	240	1 1/2	5 <sup>9</sup>	25	5 <sup>9</sup>	-	-			
	0.75	1	ATV12•075M2	15.7	960	H•L36020	5 <sup>9</sup>	yes	yes	20	5 <sup>1,2</sup>	GV2P14	240	1 1/2	5 <sup>9</sup>	25	5 <sup>9</sup>	-	-			
	1.5	2	ATV12HU15M2	15.7	960	H•L36025	5 <sup>10</sup>	no	yes	25	5 <sup>10</sup>	GV2P20	240	3	5 <sup>10</sup>	40	5 <sup>10</sup>	-	-			
240 Vac Three-phase	0.18	1/4	ATV12H018M3	15.7	960	H•L36015	5	yes	yes	10	5	GV2P07	240	1/2	5	5	5	-	-			
	0.37	1/2	ATV12•037M3	15.7	960	H•L36015	5	yes	yes	10	5	GV2P08	240	3/4	5	7	5	-	-			
	0.75	1	ATV12•075M3	15.7	960	H•L36015	5	yes	yes	15	5	GV2P14	240	3	5	15	5	-	-			
	1.5	2	ATV12•U15M3	15.7	960	H•L36015	5	yes	yes	15	5	GV2P16	240	3	5	25	5	-	-			
	2.2	3	ATV12•U22M3	15.7	960	H•L36025	5	yes	yes	25	5	GV2P20	240	5	5	25	5	-	-			
	3	3	ATV12•U30M3	15.7	960	H•L36030	5	no	yes	30	5	GV2P21	240	7.5	5	40	5	-	-			
	4	5	ATV12•U40M3	15.7	960	H•L36040	5	no	yes	40	5	GV2P22	240	7.5	5	45	5	-	-			

Altivar 12 Short Circuit Current Ratings <sup>1 2</sup>			Minimum Enclosure Volume		With Circuit Breaker		With QO Circuit Breaker				With GV•P			Fuses		Line Reactor Min Value <sup>8</sup>			
With Enclosure, With Line Reactor					PowerPact <sup>3</sup> Catalog Number (Z1, Z2)	SCCR (X)	QO QOB	QOU	Rating	SCCR (X)	GV•P (Z1, Z2)			SCCR (X)	600 V Class J <sup>5</sup> (Z1, Z2)	SCCR (X)			
Input Voltage 50/60 Hz (Y)	Power Ratings										Catalog Number <sup>7</sup>	Type E <sup>4</sup>	Voltage Rating						Power <sup>6</sup>
	(kW)	(HP)		(L)	(in3)	(kA)			(A)	(kA)	–	(V)	(HP)	(kA)	(A)	(kA)	(mH)	(A)	
120 Vac Single-phase	0.18	1/4	ATV12H018F1	15.7	960	H•L36015	22	yes	yes	10	10	GV2P10	120	1/4	22	15	22	1	4
	0.37	1/2	ATV12•037F1	15.7	960	H•L36020	22	yes	yes	20	10	GV2P14	120	1/2	22	25	22	1	7.3
	0.75	1	ATV12H075F1	15.7	960	H•L36025	22	yes	yes	25	10	GV2P20	120	1	22	40	22	1	12.8
240 Vac Single-phase	0.18	1/4	ATV12H018M2	15.7	960	H•L36015	65	yes	yes	10	10	GV2P08	240	1/3	65	7	65	2.3	2.2
	0.37	1/2	ATV12•037M2	15.7	960	H•L36015	65	yes	yes	10	10	GV2P10	240	1/2	65	15	65	2.3	4
	0.55	3/4	ATV12•055M2	15.7	960	H•L36015	65	yes	yes	15	10	GV2P14	240	1 1/2	65	25	65	2.3	7
	0.75	1	ATV12•075M2	15.7	960	H•L36020	65	yes	yes	20	10	GV2P14	240	1 1/2	65	25	65	2.3	10
	1.5	2	ATV12HU15M2	15.7	960	H•L36025	65	no	yes	25	10	GV2P20	240	3	65	40	65	1	13.2
240 Vac Three-phase	0.18	1/4	ATV12H018M3	15.7	960	H•L36015	65	yes	yes	10	10	GV2P07	240	1/2	65	5	65	6.4	1
	0.37	1/2	ATV12•037M3	15.7	960	H•L36015	65	yes	yes	10	10	GV2P08	240	3/4	65	7	65	6.4	1.6
	0.75	1	ATV12•075M3	15.7	960	H•L36015	65	yes	yes	15	10	GV2P14	240	3	65	15	65	6.4	3
	1.5	2	ATV12•U15M3	15.7	960	H•L36015	65	yes	yes	15	10	GV2P16	240	3	65	25	65	1	6.5
	2.2	3	ATV12•U22M3	15.7	960	H•L36025	65	yes	yes	25	10	GV2P20	240	5	65	25	65	1	8.6
	3	3	ATV12•U30M3	15.7	960	H•L36030	65	no	yes	30	10	GV2P21	240	7.5	65	40	65	0.8	11.3
	4	5	ATV12•U40M3	15.7	960	H•L36040	65	no	yes	40	10	GV2P22	240	7.5	65	45	65	0.8	14.1

- The amp rating of the short circuit protection devices in the table are maximum values. Smaller amp sizes may be used. Branch circuit protection must be provided in accordance with the National Electrical Code and any additional local codes.
- Ratings apply to an Altivar 12 drive mounted in a T 1, 3R, 4(X) or 12 rated enclosure. Minimum enclosure volume allows for specified SCCR. Thermal requirements may require a larger enclosure.
- Circuit breaker part number designations: ● = short circuit current rating. For 120V/240 V range, use ● = D for 25 kA, G for 65 kA, J for 65 kA, L for 65 kA, R for 65 kA.
- For GV2P/3P use, 480 V and 600 V ratings are for Wye connected electrical distribution systems. GV2P●● self protected manual combination starter must be used with GV2GH7 insulating barrier to meet UL 508 Type E rating. GV3P●● self protected manual combination starter must be used with GV3G66 + GVAM11 insulating barrier and auxiliary contact to meet UL 508 Type E rating. The GVAM11 provides a visual indication if the GV3P has tripped.
- Use Class CC or J fast acting or time delay.
- UL61800-5-1 Par. 6.3.7DV.2.1.1 require publishing the standard Type E combination motor controller power rating since this is a basic identification marking of type E devices. However, when applied as an input overcurrent protective device for a drive, the rated current of the Type E combination motor controller, not the rated power, is the key parameter for dimensioning (reference UL61800-5-1Par. 5.2.3.6.2DV.4.1.11 & 5.2.3.6.2DV.4.1.12). Schneider Electric GV•P Type E combination motor controllers are adjustable, their current range is shown on the adjustment dial and their selection is based on the input current and not the power rating of the drive.
- Catalog Number designations: ● = H for drives with heatsink and = P for drives on a base plate.
- Reactor from Altivar catalog or MTE series: RLW, do not substitute.
- Despite a 5kA SCCR, the thermal design is for 1kA as indicated in the catalog. For an operating at 5kA, do not exceed 35 °C (95 °F) ambient temperature at nominal load, or reduce slightly the load not to operate over the input current given in the catalog.
- Despite a 5kA SCCR, the thermal design is for 1kA as indicated in the catalog. For an operating at 5kA, do not exceed 45 °C (113 °F) ambient temperature at nominal load, or reduce slightly the load not to operate over the input current given in the catalog.

Note:

- Integral solid state short circuit protection in the drive does not provide branch circuit protection. Branch circuit protection must be provided in accordance with the National Electrical Code and any local codes.
- The Altivar 12 drive has a 100 kA interrupt rating on the output of the drive. In addition to providing a rating based on shorting the output of the drive, these short circuit current ratings have been obtained by shorting components internal to the Altivar 12. These ratings allow proper coordination of short circuit protection.

**DANGER**

**HAZARD OF ELECTRIC SHOCK, EXPLOSION, OR ARC FLASH**

Any association other than those provided, validated, or officially specified must undergo:

- complete normative testing,
- performed by a Certified Competent Body,
- confirming that 100% of the applicable standards remain fully covered.

**Failure to follow these instructions will result in death or serious injury.**

Without such testing and validation, system compliance can no longer be guaranteed, and Schneider Electric cannot be held responsible for any situation resulting from the customer's own choices or actions.

## Wiring

With Single-Phase Power Supply, when using GV2P and GV3P manual self-protected combination starters for single-phase input applications, wire the drive as illustrated :

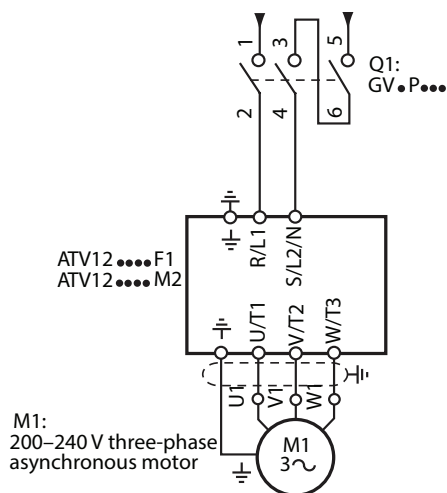

## Characteristics of the Power Part Terminals

ATV12H	Applicable wire size (1) mm <sup>2</sup> (AWG)	Recommended wire size (2) mm <sup>2</sup> (AWG)	Tightening torque (3) N·m (lb.in)
018F1 037F1 0ppM2 0ppM3	<b>2</b> to 3.5 ( <b>14</b> to 12)	2 (14)	0.8 to 1 (7.1 to 8.9)
075F1 UppM2	<b>3.5</b> to 5.5 ( <b>12</b> to 10)	5.5 (10)	1.2 to 1.4 (10.6 to 12.4)
U15M3 U22M3	<b>2</b> to 5.5 ( <b>14</b> to 10)	2 (14) for U15M3 3.5 (12) for U22M3	
U30M3 U40M3	5.5 (10)	5.5 (10)	

- (1) The value in bold corresponds to the minimum wire gauge to permit secureness.  
 (2) 75°C (167 °F) copper cable (minimum wire size for rated use)  
 (3) Recommended to maximum value.

**Schneider**  
Electric

**EAC**

Преобразователь частоты серии Altivar

Основные параметры и характеристики указаны на маркировке изделия.

Наименование страны, где изготовлено изделие, указано на упаковке.

Преобразователь частоты предназначен для управления асинхронными и синхронными электродвигателями с постоянными магнитами (может отличаться для разных типов преобразователей частоты).

Безопасность применения оборудования обеспечивается его эксплуатацией в установленных изготовителем условиях квалифицированным персоналом.

Правила и условия монтажа, хранения, перевозки (транспортирования), реализации и утилизации согласно инструкции по эксплуатации, размещенной на сайте изготовителя.

Отключите силовое питание от преобразователя частоты в случае возникновения не сбрасываемой неисправности и дождитесь погасания экрана графического терминала.

Найдите причину неисправности и устраните ее.

Подключите питание: это приведет к сбросу блокировки преобразователя частоты по ошибке, если причина возникновения устранена.

В некоторых случаях может произойти автоматический повторный запуск в работу после исчезновения неисправности и сброса ошибки, если эта функция была запрограммирована.

Уполномоченный поставщик в Республике Казахстан:

ТОО «Шнейдер Электрик»  
 Адрес: 050010, РК, г. Алматы, пр. Достык, 38,  
 Бизнес Центр «Кен Дала», 5 этаж, левое крыло.  
 Тел. +7 (727) 339 23 57  
 Номер службы поддержки клиентов:  
 Тел.: +7 (727) 339 24 52

Дата изготовления указана на упаковке (под текстом "Made in"): PРYYWW, где PР – код завода, YY – год изготовления, WW – номер недели изготовления.

Altivar сериясының жиілік түрлендіргіші

Herizgi параметрлер мен сипаттамалар өнімнің жапсырмасында көрсетілген.

Өнім шығарылған мемлекеттің атауы қаптамада көрсетілген.

Жиілік түрлендіргіші тұрақты магниттері бар асинхронды және синхронды электр қозғалтқыштарын басқаруға арналған (жиілік түрлендіргіштерінің әр түрлі типтері үшін әр түрлі болуы мүмкін).

Жабдықты пайдалану қауіпсіздігі оның өндіруші белгілеген жағдайларда білікті маманның жұмыс жасауымен қамтамасыз етіледі.

Өндірушінің веб-сайтында пайдалану жөніндегі нұсқаулыққа сәйкес орнату, сақтау, тасымалдау, сату және жою ережелері мен шарттары көрсетілген.

Қалпына келтіруге болмайтын ақаулық туындаған жағдайда электр желісін реттелетін жиіліктік жетектен ажыратыңыз және графикалық дисплей терминалы сөнгенше күтіңіз.

Мәселенің себебін тауып, оны түзетіңіз.

Қуатты қосыңыз: егер бұл себеп жойылған болса, жиілік түрлендіргішінің құлыпталуын қайта қалпына келтіреді.

Кейбір жағдайларда ақаулық жойылып, құлыпталуы қайта қалпына келтірілгеннен кейін, автоматты түрде қайта іске қосылуы мүмкін, егер бұл функция бағдарламаланған болса.

Қазақстан Республикасында ресми жеткізуші:

ЖШС «Шнейдер Электрик»  
 Мекен-жайы: Қазақстан Республикасы, Алматы қ., Достық даң. ү. 38,  
 «Кен Дала» Бизнес Орталығы, 5-ші қабат.  
 Тел.: +7 (727) 339 23 57  
 Клиенттерге қолдау көрсету нөмірі:  
 Тел.: +7 (727) 339 24 52

Дайындалу күні қаптамада көрсетілген (мәтіннің астында көрсетілген "Made in"): PРYYWW, мұндағы PР - зауыт коды, YY - дайындалу жылы, WW – дайындалу аптасы.

**MANUFACTURER**  
**Schneider Electric Industries SAS**  
 35 rue Joseph Monier  
 Rueil Malmaison 92500  
 France

**UK REPRESENTATIVE**  
**Schneider Electric Limited**  
 Stafford Park 5  
 Telford, TF3 3BL  
 United Kingdom

## China RoHS Hazardous Substances Table



The data shown in this spreadsheet are related to the following version of the China RoHS 2.0:

"Administrative Measures for the Restriction of Hazardous Substances in Electric Appliances and Electronic Products" released January 21st 2016.

部件名称 Part Name	有害物质 - Hazardous Substances					
	铅 (Pb)	汞 (Hg)	镉 (Cd)	六价铬 (Cr (VI))	多溴联苯 (PBB)	多溴二苯醚 (PBDE)
金属部件 Metal Parts	x	o	o	o	o	o
塑料部件 Plastic Parts	o	o	o	o	o	o
电子件 Electronic	x	o	o	o	o	o
触点 Contacts	o	o	o	o	o	o
线缆和线缆附件 Cables and cabling accessories	o	o	o	o	o	o

本表格依据SJ/T11364的规定编制。

O: 表示该有害物质在该部件所有均质材料中的含量均在GB/T 26572规定的限量要求以下。

X: 表示该有害物质至少在该部件的某一均质材料中的含量超出GB/T 26572规定的限量要求。

This table is made according to SJ/T 11364.

O: indicates that the concentration of hazardous substance in all of the homogeneous materials for this part is **below** the limit as stipulated in GB/T 26572.

X: indicates that concentration of hazardous substance in at least one of the homogeneous materials used for this part is **above** the limit as stipulated in GB/T 26572