



PROAIR
WATER-COOLED AIR CONDITIONER
CR43WC MODEL
INSTRUCTION MANUAL

TABLE OF CONTENTS

WARRANTY AND RETURN POLICY	2
HANDLING & TESTING THE AIR CONDITIONER	3
INSTALLATION INSTRUCTIONS	4
F-GAS INFORMATION	4
TECHNICAL INFORMATION	4
Design Data	4
DIMENSIONAL DRAWINGS	5
Components List	6
STANDARD WIRING DIAGRAM, 115 / 230 VOLT	7
TIME DELAY RELAY OPTION WIRE DIAGRAM, 115 / 230 VOLT	7
TEMPERATURE CONTROL	8
PRINCIPLES OF OPERATION	8
WATER USAGE	8
Condenser	8
Manual Reset High Pressure Limit Switch	8
Water Valve	8
Water	9
MAINTENANCE	9
Compressor	9
Evaporator Blower	9
Refrigerant Loss	9
Freezing and Draining the System	9

NOTE: Some of the information in this manual may not apply if a special unit was ordered. If additional drawings for a special unit are necessary, they have been inserted. Contact Pentair Equipment Protection if further information is required.

WARRANTY AND RETURN POLICY

<https://hoffman.nvent.com/en/hoffman/warranty-information>

RECEIVING THE AIR CONDITIONER

Inspect the thermoelectric cooler. Check for concealed damage that may have occurred during shipment. Look for dents, scratches, loose assemblies, etc. Damage evident upon receipt should be noted on the freight bill. Damage should be brought to the attention of the delivering carrier – NOT to Pentair Equipment Protection – within 15 days of delivery. Save the carton and packing material and request an inspection. Then file a claim with the delivering carrier.

Pentair Equipment Protection cannot accept responsibility for freight damages; however, we will assist you in any way possible.

HANDLING & TESTING THE AIR CONDITIONER

If it is necessary to place the air conditioner in a horizontal position after unpacking, be certain it is placed in an upright, vertical or mounting position for a minimum of five (5) minutes before operating.

Never attempt to operate the air conditioner while it is horizontal or on its side, back or front. The refrigeration compressor is filled with lubricating oil. Running the compressor without oil in the lower part of the housing will cause permanent damage to the air conditioner. This also voids the warranty.

TEST FOR FUNCTIONALITY BEFORE MOUNTING THE AIR CONDITIONER TO THE ENCLOSURE.

Refer to the nameplate for proper electrical current requirements, then connect power cord to a properly grounded power supply. Minimum circuit ampacity should be at least 125% of the amperage shown in the design data section for the appropriate model. No other equipment should be connected to this circuit to prevent overloading.

Connect to clean, pressurized water supply and provide drain.

Operate the air conditioner for five (5) to ten (10) minutes. No excessive noise or vibration should be evident during this run period. The evaporator blower (enclosure air), and the compressor should be running. The compressor is provided with automatic reset thermal overload protection. This thermo-switch is located and mounted inside the plastic enclosure clipped to the compressor. The only time this switch should operate is when the compressor overheats due to ambient air temperatures exceeding nameplate rating or if enclosure dissipated heat loads exceed the rated capacity of the air conditioner. The thermal overload switch will actuate and stop compressor operation. The blower will continue to operate and water will continue to flow for a short period. The compressor will restart after it has cooled to within the thermal overload cut-in temperature setting.

The unit will also shut down if water supply is interrupted. See WATER USAGE section.

INSTALLATION INSTRUCTIONS

1. Inspect air conditioner. Verify functionality before mounting the air conditioner, see HANDLING & TESTING THE AIR CONDITIONER on page 3
2. Using the cutout dimensions shown in this manual or the cutout template printed on the units shipping carton, prepare the air "IN" and air "OUT" openings, and mounting bolt hole pattern for the enclosure.
3. Using the gasket kit provided, install gaskets to air conditioner. See gasket kit illustration in this manual for proper location.
4. Mount air conditioner on enclosure using mounting bolts and screws provided. EZ-mount tabs can be used to hold unit on enclosure while mounting in place. Connect water inlet and outlet fittings to a clean pressurized water supply. Allow unit to remain upright for a minimum of five (5) minutes before starting. **Caution!** Air conditioner must be in upright position during operation.
5. To avoid cross-threading mounting inserts, start bolts by hand before tightening with a wrench or ratchet driver.
6. Refer to top of nameplate for electrical requirements. Connect the power cord to a properly grounded power supply. Use of an extension cord is not recommended. Electrical circuit should be fused with slow blow or HACR circuit breaker.

F-GAS INFORMATION

	CR430816GWXXX CR430826GWXXX
Refrigerant Kühlmittel Chłodziwo	R134a
GWP	1430
Factory Charge Füllmenge durch Hersteller Opłata Fabryczna	341 Grams 341 Gramm 341 Gramów
CO ₂ Equivalent CO ₂ Equivalent CO ₂ Ekwilalent	0.49 Tons 0,49 Tonnen 0,49 Tony

TECHNICAL INFORMATION

DESIGN DATA

Model	Voltage	Hertz	Full Load Amps	Phase	BTU/Hr. @ 131 F Enclosure Temperature	Maximum °F Water Temperature	Maximum Water Usage (GPM)	Shipping Weight lb./kg
CR43-0816-GWXXX	115	50/60	13.0 / 13/0	1	8500	90	1.5	137 / 62
CR43-0826-GWXXX	230	50/60	6.6 / 6.5	1	8500	90	1.5	137 / 62

-XXX will be replaced with a three-digit number designating all desired options. Consult the factory for specific model numbers.

DIMENSIONAL DRAWINGS

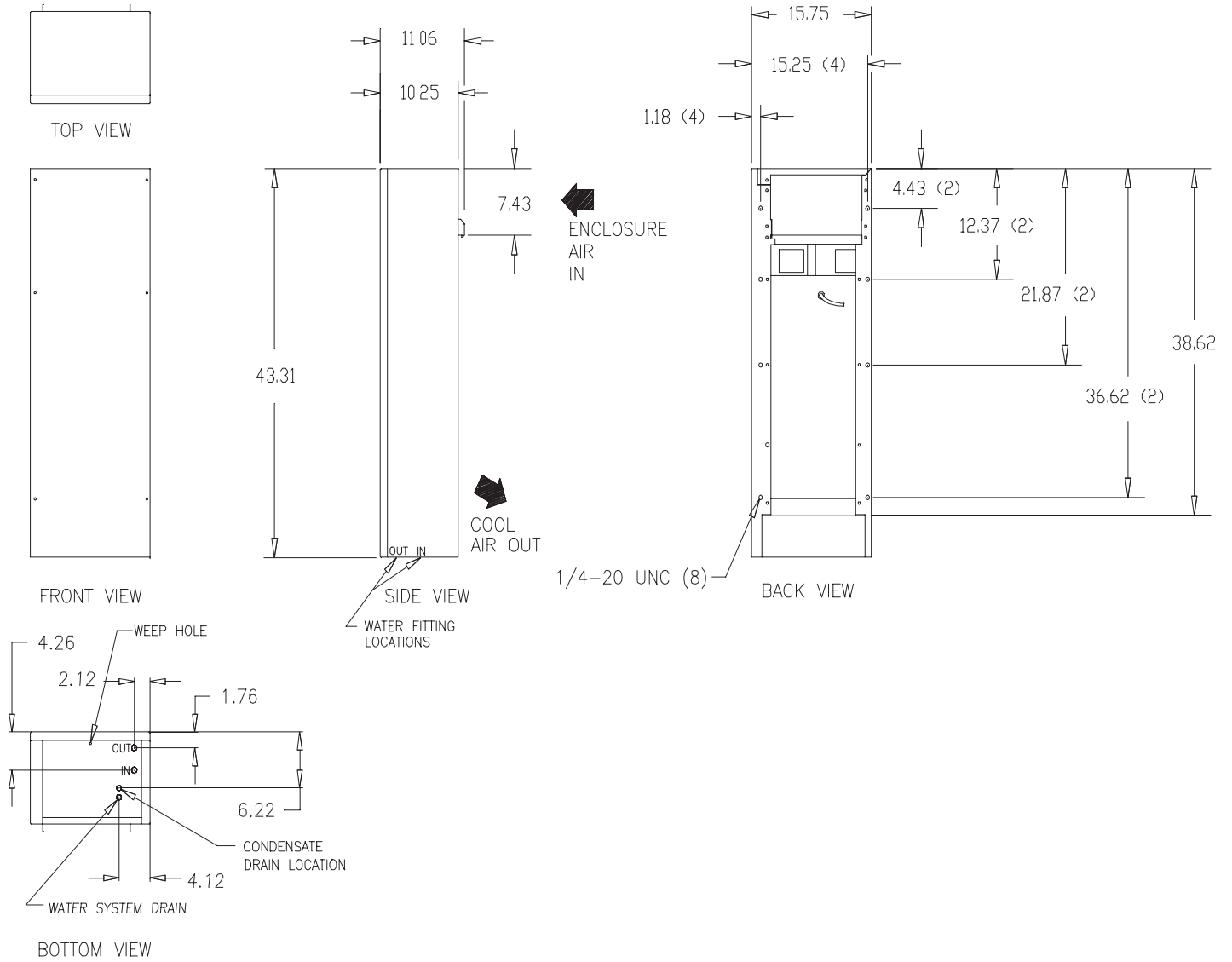

MOUNTING GASKET KIT

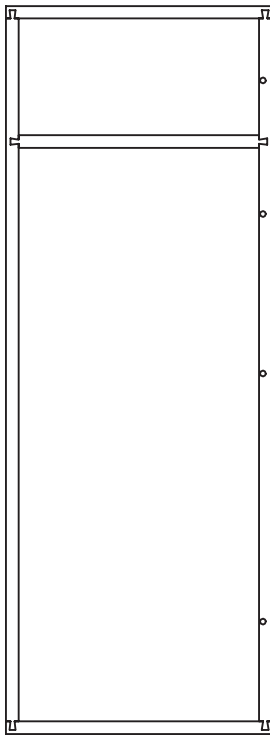

Rear view of mounting gasket kit
part number 43-2000-02

MOUNTING CUTOUT DIMENSIONS

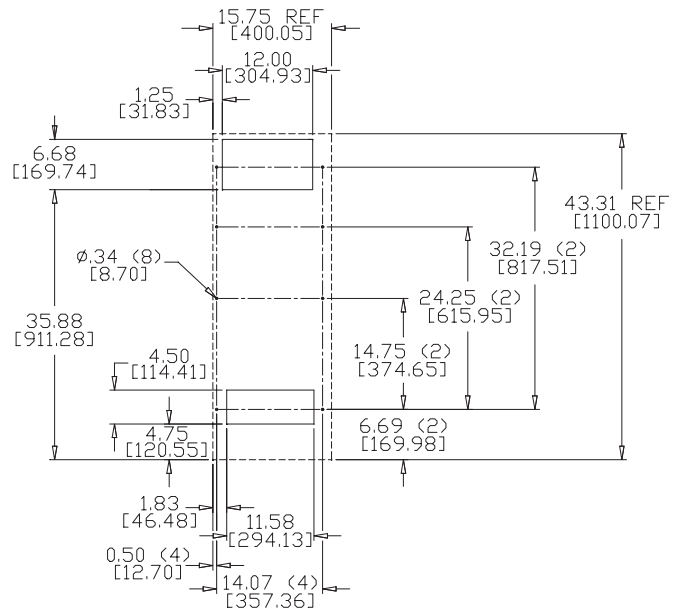

COMPONENTS LIST

Part Description	Part Number	
	115 Volt	230 Volt
Blower, Evaporator	38-2019-04	38-2020-04
Capacitor, Compressor	10-1032-15	10-1032-18
Coil, Condenser Water	47-6121-00	47-6121-00
Coil, Evaporator	43-2002-01	43-2002-01
Compressor	10-1016-68	10-1026-80
Contactator (optional)	10-1005-41	10-1005-42
Filter/Dryer	52-6028-00	52-6028-00
Relay, Compressor Start	10-1028-14	10-1028-15
Relay, Time Delay, (optional)	10-1005-71	10-1005-71
Service Cord	52-6035-01	52-6035-74
Switch, Manual Reset Pressure	52-6104-48	52-6104-48
Thermal Overload, Compressor	10-1007-50	10-1007-49
Thermostat, SPST, 55-100F	10-1061-02	10-1061-02

STANDARD WIRING DIAGRAM, 115 / 230 VOLT

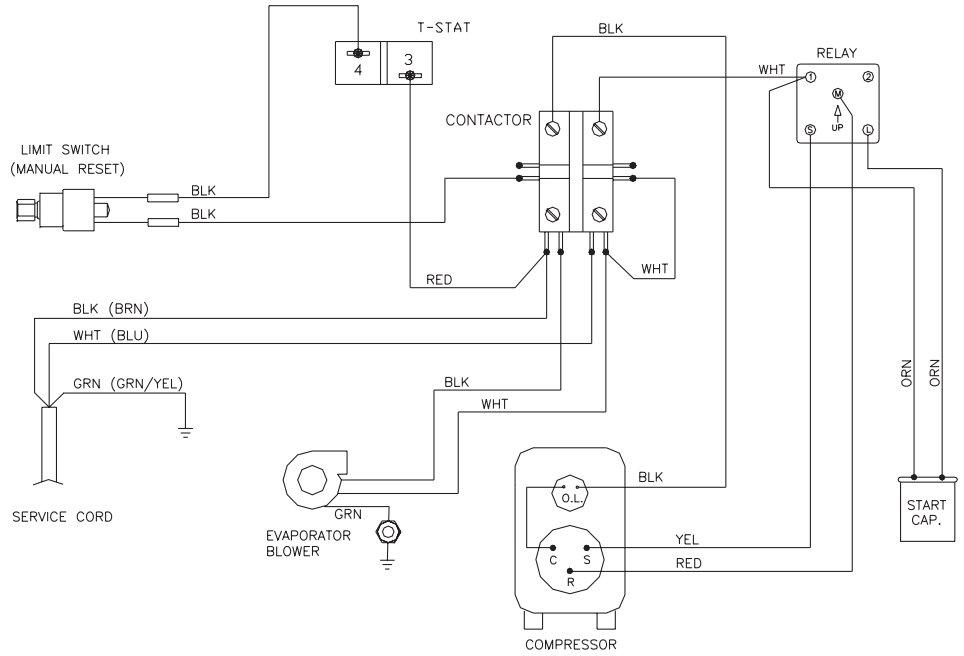
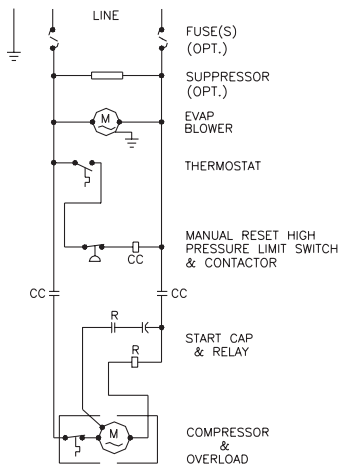

TIME DELAY RELAY OPTION WIRE DIAGRAM, 115 / 230 VOLT

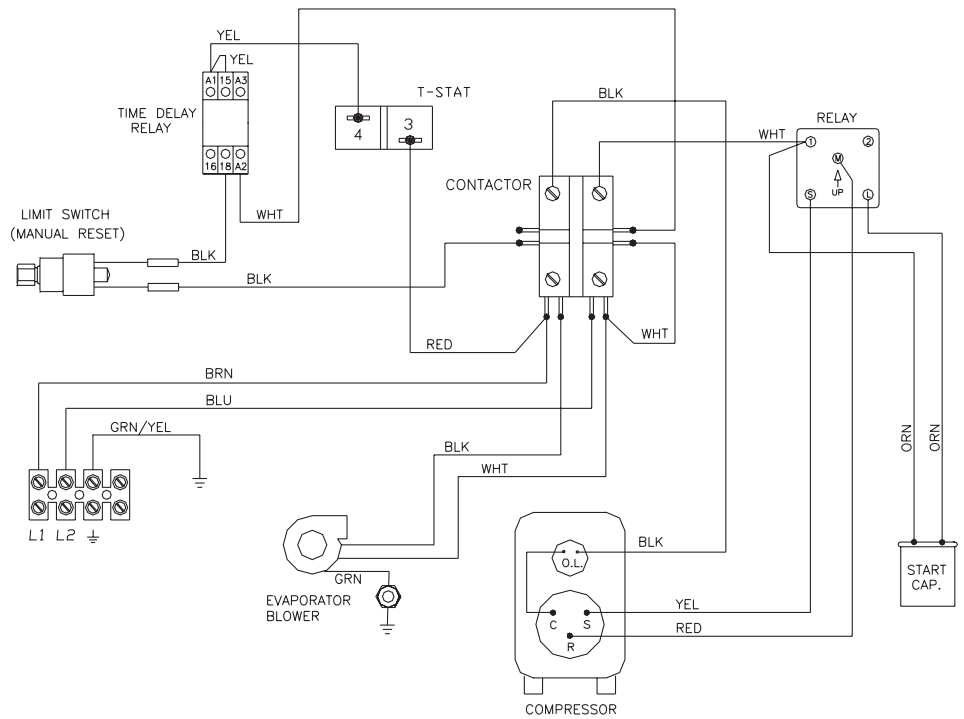
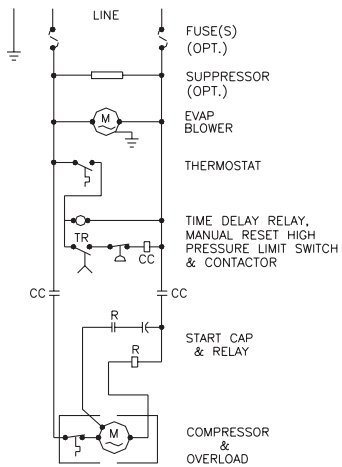

TEMPERATURE CONTROL

The electromechanical thermostat is factory preset to 75 F / 23 C. To change the temperature setting, remove the front cover. Use a standard screwdriver to adjust thermostat. For cooler temperatures turn clockwise, for warmer temperatures turn counterclockwise.

PRINCIPLES OF OPERATION

If electrical power to the air conditioner is interrupted and reapplied immediately, (within 3 to 5 seconds), the compressor may not restart due to the high back pressure of the compressor. It takes a minimum of one (1) minute after shut-down for the compressor suction and discharge pressures to equalize in order for the air conditioner to restart.

Operating the air conditioner below the minimum ambient temperature or above the maximum ambient temperatures indicated on the nameplate voids all warranties.

It is recommended that the warranty section of this manual be read in order to familiarize yourself with parameters of restricted operation.

The moisture that the enclosure air can contain is limited. If moisture flows from the drain tube continuously this can only mean that ambient air is entering the enclosure. Be aware that frequent opening of the enclosure's door admits humid air which the air conditioner must then dehumidify.

WATER USAGE

CONDENSER

The water cooled air conditioner uses water as the cooling medium for the condensing side of the hermetic refrigeration system. This water is passed through a heat exchanger that uses the cool water to lower the temperature of the hot gaseous refrigerant, causing it to condense. The water is warmed by this exchange of heat, and is passed out of the air conditioner at an elevated temperature. The inlet and outlet water fittings are located on the bottom of the air conditioner. A sealant is recommended when connecting the inlet and outlet water lines to prevent leakage. It is extremely important for the air conditioner to have an uninterrupted supply of clean cooling water. Interference with the water supply will cause the unit to automatically shut down and require manual reset.

MANUAL RESET HIGH PRESSURE LIMIT SWITCH

The manual reset high pressure limit switch is located behind the front cover. This limit switch interrupts compressor operation when condenser refrigerant exceeds 310 PSIG, which most frequently occurs as a result of the condenser water supply being reduced or shut down. After identifying and correcting the problem with the water supply to the unit, compressor operation can be restored by pushing the manual reset button located on the switch.

WATER VALVE

The valve that controls the flow of condensing water is also located behind the front cover. This valve modulates the flow of water to the condensing coil. Water flow varies according to a variety of loading conditions, including electrical load, inlet water temperature, ambient air temperature, cabinet construction, etc. The maximum flow rate in the DESIGN DATA is given for the conditions of maximum rated load, maximum water temperature, and maximum ambient temperature, and reflects the highest flow rate anticipated for the unit.

NOTE: This valve has been preset at the factory for the correct operation of the unit. The setting of the valve should not be altered.

WATER

The air conditioner water supply does not require special treatment, but care should be taken to avoid any gross contamination. Corrosives may cause leakage within the coil and water lines. Mineral rich water will cause scaling of the coil, degrading performance. Particulates may cause rapid erosion of the coil, and could result in clogging of the control valve.

NOTE: A filter to clean the air conditioner water supply is recommended.

If the temperature of the inlet water is higher than that shown in the DESIGN DATA, it will result in a higher flow rate, and may cause shut-down of the unit. High inlet water temperatures should be avoided.

When the air conditioner is shut-down, either because of a thermostatic cut-out or a loss of power, the water flow should gradually diminish to zero. If water flow persists, it may indicate a malfunction of the control valve. Information on the specific valve employed is supplied with the air conditioner.

MAINTENANCE

COMPRESSOR

The compressor requires no maintenance. It is hermetically sealed, properly lubricated at the factory and should provide years of satisfactory operating service.

Should the refrigerant charge be lost, recharging ports (access fittings) on the suction and discharge sides of the compressor are provided for recharging and/or checking suction and discharge pressures.

Under no circumstances should the access fitting covers be loosened, removed or tampered with.

Breaking of seals on compressor access fittings during warranty period will void warranty on hermetic system.

Recharging ports are provided for the ease and convenience of reputable refrigeration repair service personnel for recharging the air conditioner.

EVAPORATOR BLOWER

Blower motors require no maintenance. All bearings, shafts, etc. are lubricated during manufacturing for the life of the motor.

REFRIGERANT LOSS

Each air conditioner is thoroughly tested prior to leaving the factory to insure against refrigeration leaks. Shipping damage or microscopic leaks not found with sensitive electronic refrigerant leak detection equipment during manufacture may require repair or recharging of the system. This work should only be performed by qualified professionals, generally available through a local, reputable air conditioning repair or service company.

Refer to the data on the nameplate which specifies the type of refrigerant and the charge size in ounces.

Before recharging, make sure there are no leaks and that the system has been properly evacuated into a deep vacuum.

FREEZING AND DRAINING THE SYSTEM



WARNING

The air conditioner can be severely damaged by freezing if not properly drained. Damage due to freezing is not covered by the warranty.

If the unit is to be shipped to, or stored in an area that experiences climatic extremes, care must be taken to fully drain the unit to avoid freezing. The location of the drain is shown in the OUTLINE DRAWING. To completely drain the unit, it is recommended that 100 psi maximum compressed air be applied to the water inlet, while lifting the spring of the valve with a screwdriver to allow free passage of water. An alternate means would be to start the air conditioner and allow the refrigeration system pressure to open the valve while air pressure is applied to inlet.

NOTES

NOTES



nVent
2100 Hoffman Way
Anoka, MN 55303 USA
☎ +1.763.422.2211
☎ +1.763.576.3200

nVent.com