

## OPERATOR ADAPTER ABBLC

Installation Instructions for ABB Cable Controlled, Large Handle, Disconnect Switches  
(For parts list, see Page 2)

For floor-mounted enclosures with  
the disconnect on the right flange

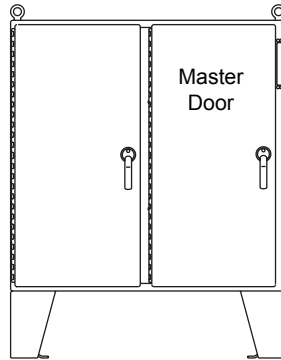

For one- through six-door free-standing enclosures  
with the disconnect the the right flange

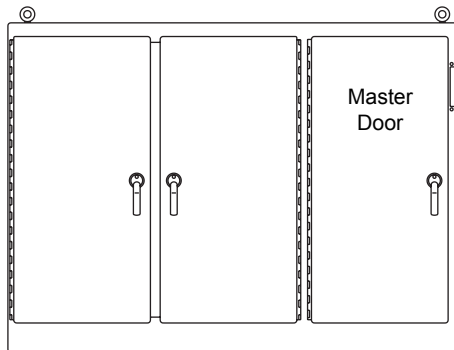

For floor-mounted enclosures with  
the disconnect on the centerpost

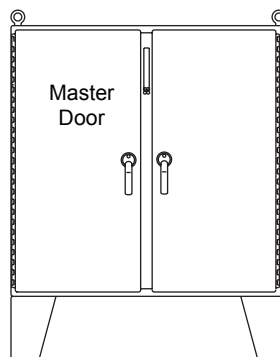

## **WARNING**

The functions, fits, and clearances of the installation described hereon are calculated from information supplied by the manufacturers of the equipment to be installed. Be certain to check the function, fits, and clearances of all equipment both before and after installation to assure that it operates properly and safely and meets all applicable codes, standards, and regulations.

In the event the completed installation does not function properly or fails to meet any such codes, standards, or regulations, do not attempt to make alterations or operate the equipment. Report such facts immediately to:

Hoffman Customer Service  
2100 Hoffman Way  
Anoka, MN 55303  
763 422 2211  
<http://hoffman.nvent.com/contact-us>

### Parts List

Operator Adapter, Catalog Number ABBLC, for ABB Cable Controlled Large Handle Disconnects

Item No.	Description	Part No.	Qty.
1	ADAPTER PLATE	27317001	1
2	PLATE GASKET	89109613	1
3	SCREW, 1/4-20X1/2 PAN HEAD	99401031	4
4	SLIDE ARM	27217001	1
5	SHOULDER COLLAR	27112001	1
6	SCREW, 5/16-18X1 HEX HEAD	99401081	1
7	LOCKWASHER, 5/16 SPRING	99401305	1
8	WASHER, FLAT	22101003	2
9	LOCKWASHER, 1/4 INTERNAL TEETH	99401300	2
10	NUT, 1/4-20 HEX	99401406	2
11	DOOR CATCH, ABB	89114410	1
12	SCREW, 10-32X3/8 PAN HEAD	99401007	2
13	LOCKWASHER, #10 INTERNAL TEETH	99401307	2
14	NYLON WASHER	26132003	4
15	INSTALLATION INSTRUCTIONS	89114657	1

## INTRODUCTION

This installation instruction is for ABB Cable Controlled Large Handle mechanisms. These mechanisms are for disconnect switches and circuit breakers mounted in Hoffman two-door, floor-mounted and one- through six door, free-standing enclosures with the disconnect on the right flange.

## INSTALLATION STEPS

### Step 1

Install adapter plate (item 1) and plate gasket (item 2) on the inside of the enclosure, behind the rectangular opening provided. Gasket side with PSA should be attached to the adapter plate. Secure in place with four screws (item 3), and four nylon washers (item 14).

### Step 2

Assemble the ABB operating handle to the mounting plate which was installed in the enclosure in step 1. Omit cap screw and lockwasher which fits into bottom hole of ABB operating handle.

### Step 3

Install the slide arm (item 4) over the interlock lever part of the ABB operating handle, as shown. Note that the notch in the slide arm is positioned toward the door opening. Place the smaller diameter end of the shoulder collar (item 5) through the oval slot in the slide arm. Install long cap screw (item 6) with lockwasher (item 7) through shoulder collar into the bottom mounting hole of the ABB operating handle and tighten. The slide arm should move up and down smoothly. Install interlock lever extension per ABB instructions.

### Step 4

Attach the bottom of the slide arm to the offset arm of the lock release mechanism. Use two flat washers (item 8), two lockwashers (item 9), and two hex nuts (item 10). Do not tighten until parts are adjusted. (see step 5B)

### Step 5

The handle safety lock release mechanism is adjustable in two places.

(A) Check the adjustment of the factory installed roller bracket. The door latch should hit against the latch stop portion of the roller bracket when the door is closed and latched. Adjust up or down if necessary. The attached mechanism will then provide the necessary up-down motion required to operate the release mechanism in the ABB operating handle.

(B) Adjust the length of the slide arm assembly. With proper adjustment of the slide arm, the safety lock (in ABB operating handle) should release just before the master door is fully latched. Lengthen slide arm if safety lock releases too soon. Shorten slide arm if safety lock releases too late.

### Step 6

Attach the door catch (item 11), provided by Hoffman, to the tapped spacer on the door using the bottom set of mounting holes. Use two screws (item 12) and lockwashers (item 13). The door catch prevents the door from being opened when the ABB operating handle is in the "ON" position.

### Step 7

Drill and tap holes in panel per ABB instructions. Disconnect can be located anywhere within reach of cable length being used. See ABB instructions.

### Step 8

Install panel on collar studs in enclosure.

### Step 9

Mount disconnect switch or circuit breaker and operating mechanism on panel using ABB instructions and parts.

For Two-Door, Floor-Mounted and One- Through Six-Door, Free-Standing Enclosures with Disconnect on Right Flange

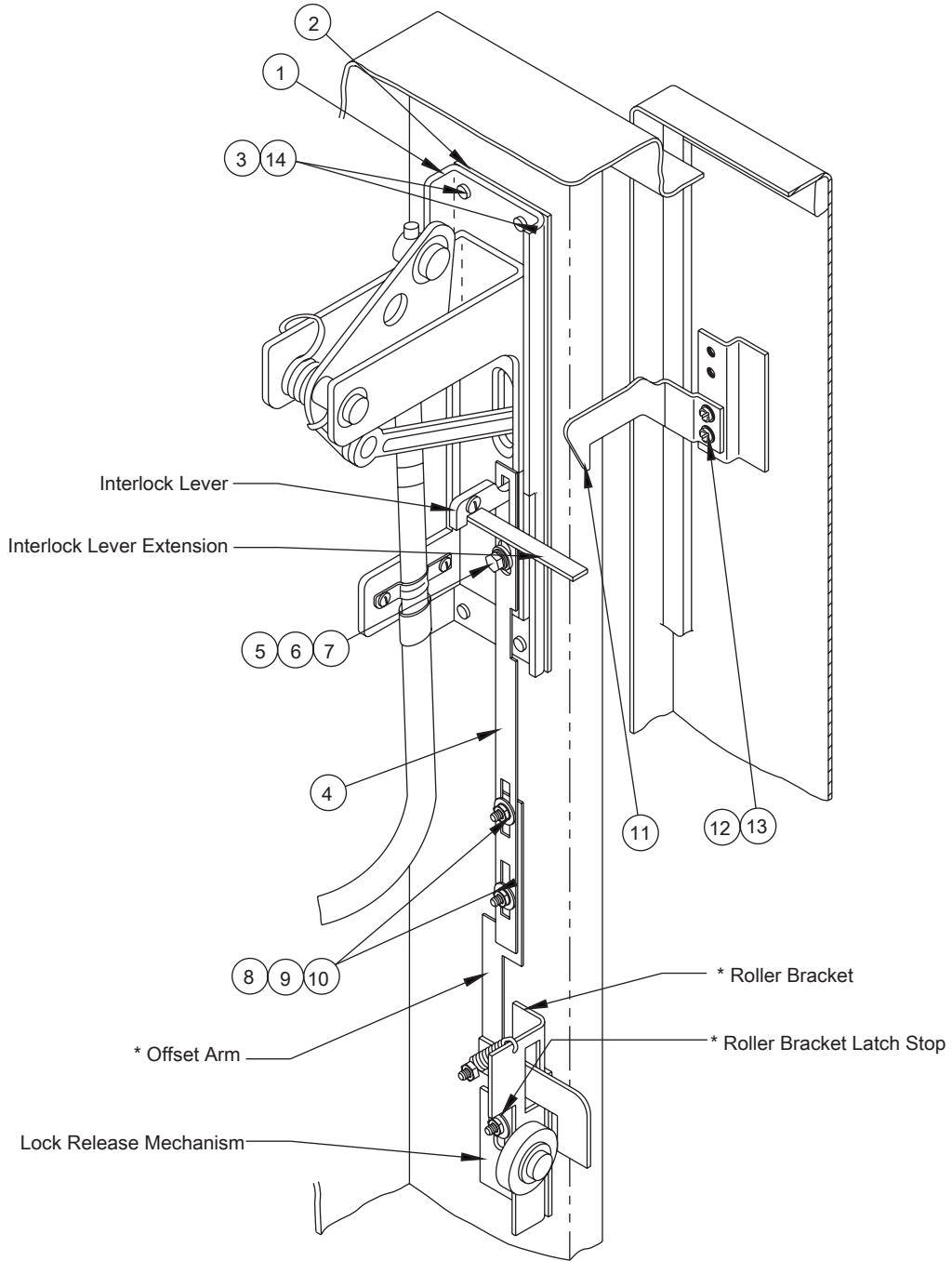

\* Parts of Lock Release Mechanism

## INTRODUCTION

This installation instruction is for ABB Cable Controlled, Large Handle, mechanisms. These mechanisms are for disconnect switches and circuit breakers mounted in Hoffman two-door, floor-mounted enclosures with the disconnect on the centerpost.

## INSTALLATION STEPS

### Step 1

Install adapter plate (item 1) and plate gasket (item 2) on the inside of the enclosure, behind the rectangular opening provided in the centerpost. Gasket side with PSA should be attached to the adapter plate. Secure in place with four screws (item 3) and four nylon washers (item 14).

### Step 2

Assemble the ABB operating handle to the mounting plate which was installed in the enclosure in step 1. Omit cap screw and lockwasher which fits into bottom hole of ABB operating handle.

### Step 3

Cut 2 1/2" off bottom end of slide arm (item 4) (bottom end has rectangular holes only).

### Step 4

Install the slide arm (item 4) over the interlock lever part of the ABB operating handle, as shown. Place the smaller diameter end of the shoulder collar (item 5) through the oval slot in the slide arm. Note that the notch in the slide arm is positioned toward the door opening. Place the smaller diameter end of the shoulder collar (item 5) through the oval slot in the slide arm. Install long cap screw (item 6) with lockwasher (item 7) through shoulder collar into the bottom mounting hole of the ABB operating handle and tighten. The slide arm should move up and down smoothly. Install interlock lever extension per ABB instructions.

### Step 5

Attach the bottom of the slide arm to the offset arm of the lock release mechanism. Use two flat washers (item 8), two lockwashers (item 9), and two hex nuts (item 10). Do not tighten until parts are adjusted.

### Step 6

Adjust the length of the slide arm assembly. With proper adjustment of the slide arm, the safety lock (in ABB operating handle) should release just before the master door is fully latched. Lengthen slide arm if safety lock releases too soon. Shorten slide arm if safety lock releases too late.

### Step 7

Attach the door catch (item 11), provided by Hoffman, to the tapped spacer on the door using the bottom set of mounting holes. Use two screws (item 12) and lockwashers (item 13). The door catch prevents the door from being opened when the ABB operating handle is in the "ON" position.

### Step 8

Drill and tap holes in panel per ABB instructions. Disconnect can be located anywhere within reach of cable length being used. See ABB instructions.

### Step 9

Install panel on collar studs in enclosure.

### Step 10

Mount disconnect switch or circuit breaker and operating mechanism on panel using ABB instructions and parts.

# For Two-Door, Floor-Mounted Enclosures with Disconnect on Centerpost

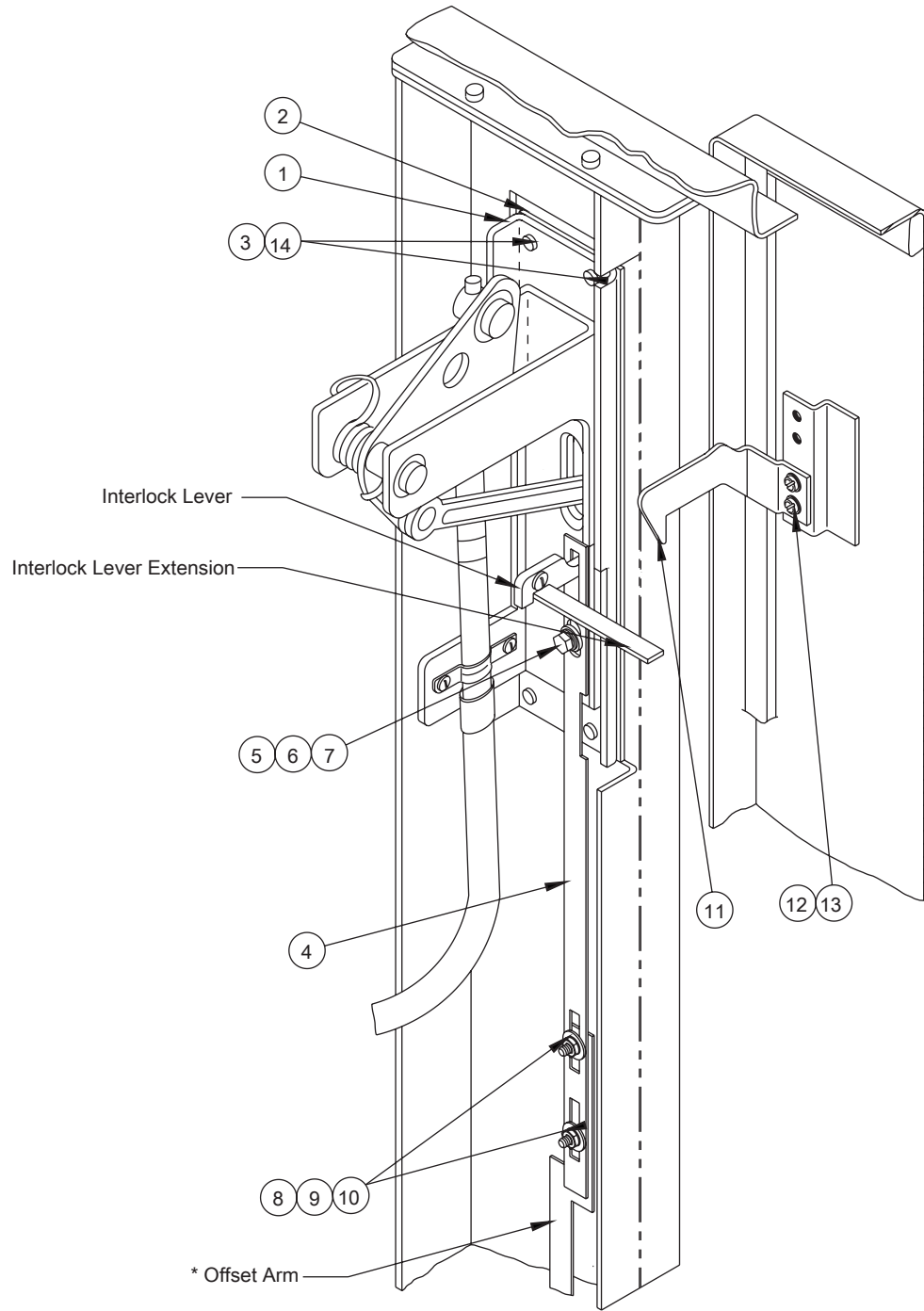

\* Parts of Lock Release Mechanism