

THIS COPY IS PROVIDED ON A RESTRICTED BASIS AND IS NOT TO BE USED IN ANY WAY DETRIMENTAL TO THE INTERESTS OF PANDUIT CORP.

| PANDUIT PART # | STUD SIZE |        | DIMENSIONS in. [mm] |               |               |               |               |
|----------------|-----------|--------|---------------------|---------------|---------------|---------------|---------------|
|                | ENGLISH   | METRIC | L ± .04 [1,0]       | W ± .01 [0,3] | C ± .02 [0,5] | M ± .04 [1,0] | H ± .01 [0,3] |
| PN10-8R-2K     | #8        | M4     | 1.21 [30,7]         | .38 [9,7]     | .31 [7,9]     | .88 [22,4]    | .17 [4,3]     |
| PN10-10R-2K    | #10       | --     | 1.06 [27,0]         | .38 [9,7]     | .31 [7,9]     | .88 [22,4]    | .20 [5,1]     |
| PN10-14R-2K    | 1/4"      | M6     | 1.21 [30,7]         | .52 [13,2]    | .38 [9,7]     | .95 [24,1]    | .27 [6,9]     |
| PN10-56R-2K    | 5/16"     | M8     | 1.21 [30,7]         | .52 [13,2]    | .38 [9,7]     | .95 [24,1]    | .33 [8,4]     |
| PN10-38R-2K    | 3/8"      | --     | 1.29 [32,8]         | .58 [14,7]    | .43 [10,9]    | .95 [25,4]    | .39 [9,9]     |

NOTES:

- USED FOR:
  - A. #12-10 AWG [4,0-6,0 mm<sup>2</sup>] SOLID OR STRANDED COPPER WIRE
  - B. 221°F [105°C] MAX. OPERATING TEMPERATURE
  - C. 600 V. MAX. VOLTAGE RATING
- INSTALLATION TOOLS:
  - A. PRESSES : CP-861, CP-871
  - B. APPLICATOR: CA-800, CA-9
  - C. DIE INSERTS: CD-800-3, CD9-3
- WIRE STRIP LENGTH: 9/32" <sup>+1/32</sup>/<sub>0</sub> [7,1<sup>+0,8</sup>/<sub>0</sub>]
- MATERIAL:
  - A. STAMPING: .04" [1,02] THK COPPER, TIN PLATED
  - B. HOUSING: NYLON, YELLOW
  - C. SLEEVE: BRASS, TIN PLATED
- VISIT OUR ON-LINE CATALOG AT WWW.PANDUIT.COM FOR A LIST OF CURRENT PARTS APPLICABLE FOR USE WITH THIS PRODUCT.
- DIMENSIONS IN ( ) ARE METRIC.

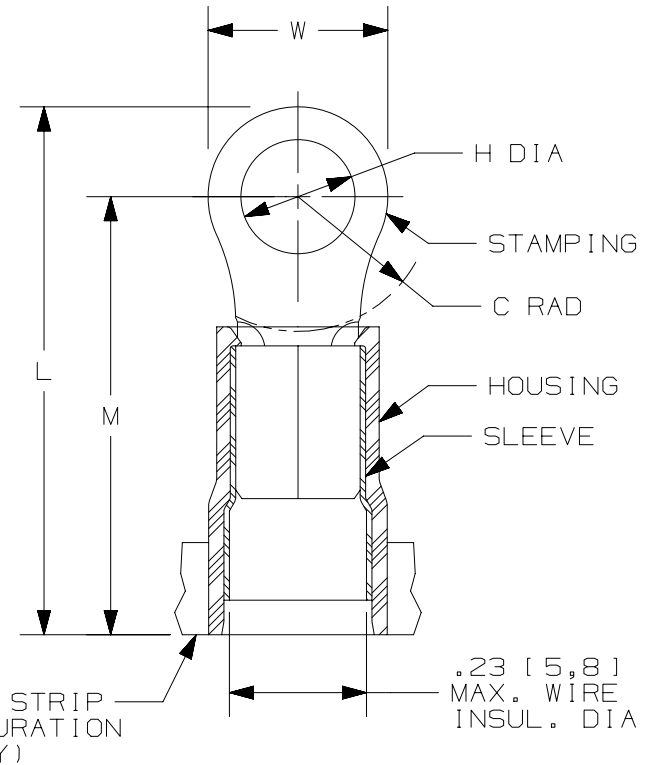

LISTED  
587H  
E52164



CERTIFIED  
LR31212

|   |          |  |            |
|---|----------|--|------------|
| PART NUMBER   |          | SEE TABLE                                    |            |
| TITLE   |          | RING TERMINALS, 3PC. NYLON INSULATED, #12-10 |            |
| CUSTOMER DRAWING  |          |  |            |
| ITEM REVISION NAME  |          | N41098BA/09                                  |            |
| DATASET FILE NAME   |          | N41098BA_DC/09A                              |            |
| MATERIAL  |          | SEE NOTES                                    |            |
| DRAWING NUMBER  |          | A41098                                       |            |
| REV   | DATE     | BY   | CHK        |
| 09  | 10/15/25 | USR 094325                                   | USR 094325 |
| 08  | 09/12    | JBN  | LCA        |
| DESCRIPTION   |          | ECN  |            |
| REMOVED MILITARY SPEC. REMOVED PN10-6R, PMN6-3R & PMN6-5R. ADDED -2K TO PART #. |          | 022714/00                                    |            |
| ADDED METRIC EQUIVALENT. REVISED NOTES. UPDATED DRAWING TO CURRENT STANDARDS.   |          | A41098                                       |            |
| REV   | DATE     | BY   | CHK        |
| JMV   | -        | FS   | N.T.S.     |
| SHEET 1 OF 1  |          | A  |            |

A-SIZE CUSTOMER