

OVERVIEW

The SBGR PC Series of on/off outdoor rated photocell sensors provides intelligent control of lighting for daylight harvesting applications. Designed to recess mount into a 2.65" (6.73 cm) square opening in a fixture, the sensors work by monitoring daylight conditions, then controlling connected lighting so as to insure that adequate lighting levels are maintained. The SBGR PC provides on/off style photocell control; turning off the lights when sufficient daylight is present and turning them on when additional lighting is necessary. The SBGR PC Series sensors are line powered and can switch loads directly without the need for a power pack. To add dimming control to the on/off control provided by the SBGR PC, see the data sheet on the SBGR PC ADC sensor.

FEATURES

- Auto Set-Point Calibration Mode
- Compatible w/ LEDs, Electronic & Magnetic Ballasts, CFLs, & Incandescents
- Self-Contained Relay(s), No Power Pack Needed
- IP65 Rated for Outdoor Applications
- Digital Set-Point Control
- Interchangeable Hot & Load Wires, Impossible to Wire in Reverse
- Push-Button Programmable Adjustable Transition Delays
- 100 hr Lamp Burn-in Timer
- Green LED Indicator

Warranty

Five-year limited warranty. This is the only warranty provided and no other statements in this specification sheet create any warranty of any kind. All other express and implied warranties are disclaimed. Complete warranty terms located at: www.acuitybrands.com/support/warranty/terms-and-conditions

Note: Actual performance may differ as a result of end-user environment and application. Specifications subject to change without notice



*SBGR PC
Embedded Small Box
Photocell Sensor*



ORDERING INFORMATION

SBGR PC		Example: SBGR PC DZ WH			
Series	Dual Zone	Voltage		Color	
SBGR PC Embedded Small Box Photocell Sensor	[blank] Single Zone DZ Dual Zone	[blank] 120-277 VAC HVOLT 347-480 VAC	WH White BL Black		

AUTOMATIC SET-POINT CALIBRATION

LIGHT LEVEL SET-POINT

The sensor functions by comparing the amount of daylight available with a defined acceptable lighting level. This threshold, called the set-point, is utilized in all daylight harvesting lighting control decisions. The sensor can find its optimum set-point via the **Automatic Set-Point Programming** mode. In this mode, the sensor sets the minimum light level to be the amount contributed by the artificial lights being controlled. It is assumed that the area is properly lit by design, however, if this is not the case the set-point may be easily adjusted. All modes and settings are entered digitally via a push button sequence. Once programmed, the exact value of the set-point (in foot candles) can be read out from the sensor via a series of LED flashes.

DIGITAL SET-POINT CONTROL

Each sensor contains a microcontroller that enables the user to engage the Automatic Set-Point Programming mode or to manually set / adjust the set-point. The manual process involves calculating and inputting the exact foot-candle value of the desired set-point into the sensor. It is important to note that the set-point is the light level required at the face of the sensor and that this value will be much different than the level required at lower heights. Typically, light levels at the sensor are 3 to 5 times less than a work surface. For example, if 50 fc is desired at a work surface, the sensor should be set at 10 fc. For best results, measure the levels at both locations using a foot-candle meter before programming the set-point.

WIRING (DO NOT WIRE HOT)

STANDARD WIRING

BLACK* - Line Input
 BLACK* - Load Output } *BLACK wires can be reversed
 WHITE - Neutral

347 VAC OPTION (347)

Black wires are replaced w/ Red wires

DIMMING OPTIONS (D, ADC)

VIOLET - Connect to Violet control wire from 0-10 VDC dimmable ballast

PINK** - Connect to Gray common wire from ballast

INITIAL POWER UP

The sensor's relay is shipped in a latched closed position so the lights will come on upon initial power-up. If the lights do not immediately turn on (initial installation only) the latching relay opened during shipment and will close within 30 secs.

Note: If the sensor loses power, the internal relay will latch to on.

**0-10V Dimming Common from luminaire may be pink or as otherwise indicated per section 410.69 of the 2020 NEC

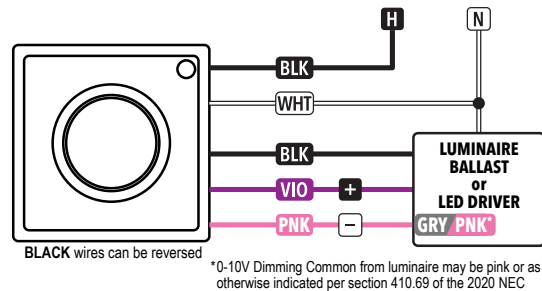

SENSORS IN PARALLEL

Sensors may be wired in parallel; however, the maximum load ratings stay the same. Do not wire sensors with P or ADC option in parallel.

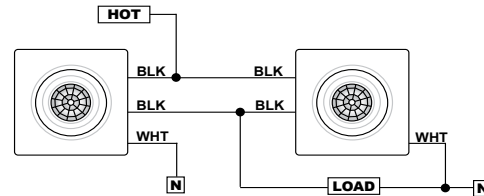

INSTALLATION

- The SBGR Series offers a custom look for recess mounting in lighting fixtures. It mounts inside a 2.65" square opening in a fixture (minimum depth 1.50"). A #6 screw with a max head height of .130 inches is recommended.
- Sensor will detect motions crossing segments more effectively than motions parallel to beams
- For optimal detection, position sensor such that segments are crossed upon entrance and unable to view outside the space

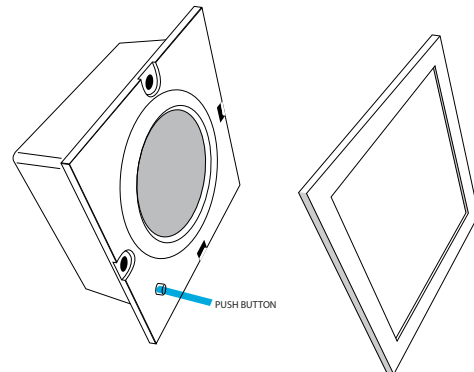

SPECIFICATIONS

Electrical

Input Ratings	120-277V, 80 mA, 50/60Hz 347V, 50 mA, 50/60Hz 480V, 60 mA, 50/60Hz
Output Ratings	120V, 800W/6.67A - Tungsten, Standard Ballast, Electronic Ballast 277V, 1385W/5A - Tungsten 277V, 1200VA/4.3A - Standard Ballast, Electronic Ballast 347V, 1500VA/4.3A - Standard Ballast 480V, 2400VA/5A - Standard Ballast 120V, 1/2HP - Motor
Low Voltage Output Ratings	0-10VDC, Sinks <20mA (With Dimming Options; D/ADC/ODP)
Relay Type	Latching
Class Rating	0-10V Dimming can be wired Class 1 or 2
Standards/ Ratings	Energy Management Equipment, UL916 (E167435)

Mechanical

Dimensions	3.40"H x 3.40"W x 1.40"D (86mm x 86mm x 36mm)
Mounting	Recessed
Connection Type	Line-Voltage Leads

Environmental

Warrantied Operating Temperature	14°F to 140°F (-10°C to 60°C)
Relative Humidity	Up to 90%, Non-Condensing
Environment	Indoor/Outdoor
Standards/ Ratings	IP66 (IEC60529) when mounted in an IP66 enclosure, RoHS
